

ASTRO-PHYSICS MODEL 900 GERMAN EQUATORIAL WITH DUAL AXIS QUARTZ DRIVE (900HDA)

MODEL 900 PARTS LIST

- 1 Polar axis assembly (right ascension-R.A.) with stepper drive
- 1 Declination (Dec.) axis assembly with stepper drive
- 1 Pier top adapter with six 5/16-18 x 5/8" button head screws with washers
(These will be attached to your pier post if you ordered one)
- 1 Stainless counterweight shaft with washer stop and black plastic knob (knob has 5/16 thread)
- 1 Dual axis quartz frequency control box
- 1 "Y" connector cable
- 1 D.C. power cord (cigarette lighter adapter on one end)
- 1 Hex key set
- 1 Piece of Velcro (to attach hand controller to surface of your choice)

In order to fully assemble your mount, you will need the following separately sold items: mounting plate, pier, counterweights, and portable rechargeable battery pack. Several sizes and types are available for your selection. Many of these items will be discussed throughout these instructions.

Several additional options will help to enhance your observing experience: polar alignment scope, JMI computerized digital setting circles, and Santa Barbara Instrument Group ST-4 or ST-6 CCD Imaging camera/autoguider, trays for your pier and 12 volt rechargeable battery.

INTRODUCTION

We recommend that you familiarize yourself with the assembly and basic operation of the mount indoors. The temperature will be comfortable, the mosquitoes at bay, and you'll have enough light to see the illustrations and read the manual. Please take particular note of counterbalancing, use of the clutches and operation of the hand controller.

WHY POLAR ALIGN?

If you were to take a long exposure photograph with Polaris (often called the North Star) in the center of the field, you would discover that all stars seem to revolve around Polaris. This effect is due to the rotation of the earth on its axis. Motor driven equatorial mounts were designed to compensate for the earth's rotation by moving the telescope at the same rate and opposite to the earth's rotation. When the polar axis of the telescope is pointed at the celestial pole (polar aligned) as shown in the diagram to the right, the mount will follow (track) the motions of the sun, moon, planets the stars. As a result, the object that you are observing will appear motionless as you observe through the eyepiece or take astrophotos.

For visual observation, a rough sighting of Polaris through the hole in the polar axis is fine. However, if astrophotography is your goal, accurate polar alignment is critical.

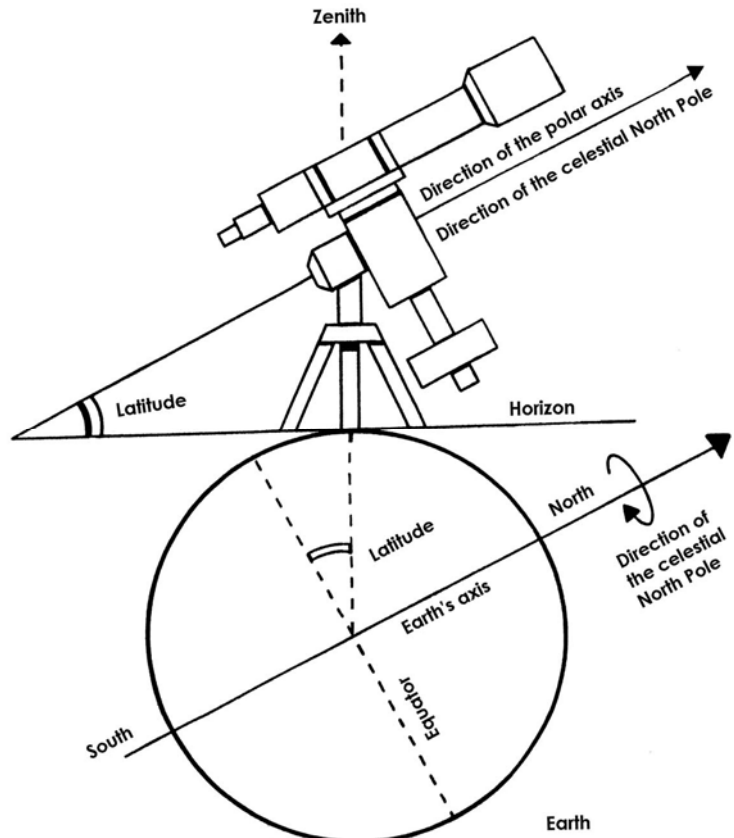

ASSEMBLY INSTRUCTIONS

Please read all instructions before attempting to set up your 900 mount. The Model 900 is very rugged; however like any precision instrument, it can be damaged by improper use and handling. Please refer to the diagram below for an illustration of the mount. The parts are labeled so that we can establish common terminology.

The following terms and abbreviations may be used interchangeably in these instructions:

Polar axis = R.A. axis = R.A. housing
Declination axis = Dec. axis = Dec. housing

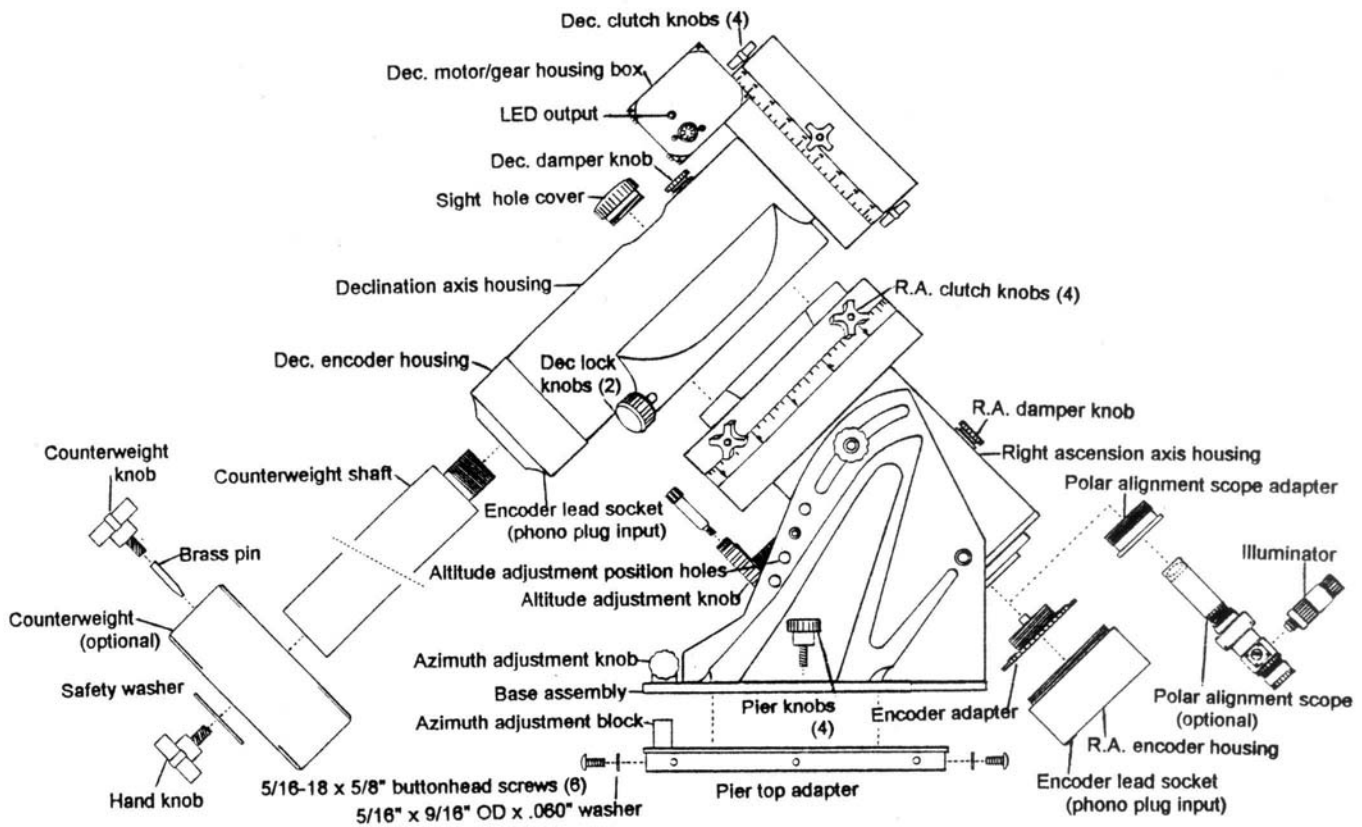

BEFORE YOU LEAVE HOME

Since most of us must set up our instruments in the dark, in the cold, or while battling mosquitoes, a bit of preplanning and organization is important. There are a few simple things that can be accomplished in the comfort of your home before heading outside.

GROSS LATITUDE ADJUSTMENT: The latitude range of the 900 mount is approximately 20-68 degrees. Since most astronomers typically observe within one latitude range, this adjustment is made just once, if at all. Prior to shipment, we preset the mount to your latitude range for your convenience. If you travel to another observing location, determine the latitude of your observing site and make the appropriate adjustment.

The four positions for the altitude adjustments have the following ranges:

- 52 degrees to 68 degrees latitude – top position
- 41 degrees to 59 degrees latitude – third position
- 30 degrees to 45 degrees latitude – second position
- 20 degrees to 34 degrees latitude – bottom position

How to change the position of the altitude adjuster bar

1. Use only the R.A. axis. DO NOT attempt to make these adjustments with the declination axis in place and certainly not with an instrument fully mounted.
2. Loosen both altitude locking knobs about one turn.
3. Locate the side of the polar axis that does **not** have the motor/gear housing box. Loosen (about one turn) the polar axis pivot screw and altitude adjuster bar, fixing screw on this side only. With your hand, push the polar axis upwards so that the altitude locking knobs are positioned at the top of the altitude slot (this is the maximum altitude position). Some resistance will be felt with this operation as you are pushing against the weight of the polar housing and the resistance of the remaining polar axis pivot screw (which has **not** been loosened).
4. Before attempting to move the altitude adjuster bar, you must tighten the altitude-locking knob on the motor/gear housing side. This will prevent any downward movement of the polar axis during positioning of the altitude adjuster bar.
5. While supporting the altitude adjuster bar, remove the two screws that support it on either side, but keep the two ends of the bar in contact with the side of the mount, don't remove it completely. This tip is for your convenience.

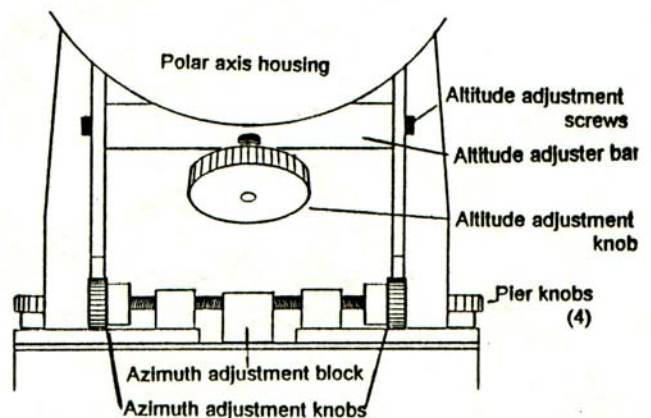
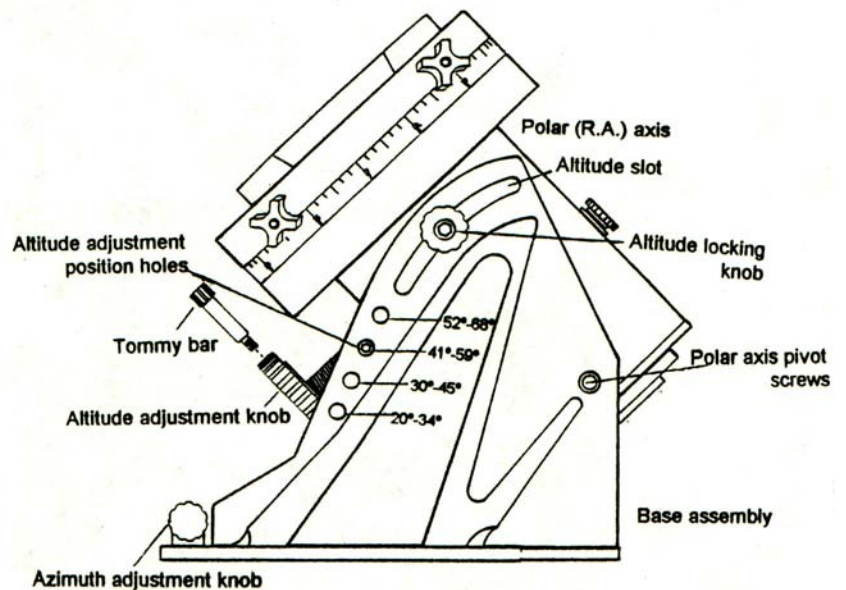

6. Guide (wiggle) the bar to the desired position, insert the screws in both ends, and lightly tighten so that you still have some ability to move the bar.
7. Note that the altitude adjustment knob is attached to a threaded rod that travels through the altitude adjuster bar. Turn the knob so that the altitude adjuster bar is positioned approximately in the middle of the threaded rod. You should see about half of the threaded rod protruding from both sides of the altitude adjuster bar. This will allow you to move the mount fully within the altitude range.
8. At the end of the threaded rod mentioned in the last step, you will see a small brass altitude adjuster thrust pad. This is the part that will come in contact with the polar axis as you ease it back into position. Loosen the altitude locking knob (motor/gear side) and lower the polar axis so that it rests comfortably on this pad. The threaded rod should be positioned at a right angle to the polar axis housing. Firmly tighten the altitude adjustment screws.
9. Turn the altitude adjustment knob to raise or lower the polar axis to your approximate observing latitude. Tighten the altitude locking knobs with finger pressure only. You do not need to tighten with the hex key.
10. Firmly tighten both polar axis pivot screws with the hex key.

ATTACH PIER ADAPTER TO PIER POST: If you purchased the pier from Astro-Physics, the pier top adapter of the 900 is already attached to the top of the pier. If you are constructing your own pier or tripod, you will need to incorporate this part. The pier adapter was designed to fit into an 8" x 0.125" wall tube. Use six (6) screws to attach this part. With the Astro-Physics pier, you can choose a "north" or "south" facing pier leg by orienting the pier adapter within the post.

ASSEMBLE PIER

Begin by assembling the portable pier at the desired observing location. Take note which direction is north.

1. Slide the three legs onto the nubs of the base and rotate the assembly so that one of the legs points toward north (or south if this is your preference).
2. Place the pier tube on the base orienting the center azimuth block directly over the leg that is oriented to the north(south).
3. Attach the tension rods. The turnbuckles should be drawn tight until the whole assembly is stiff enough to support your weight without movement.

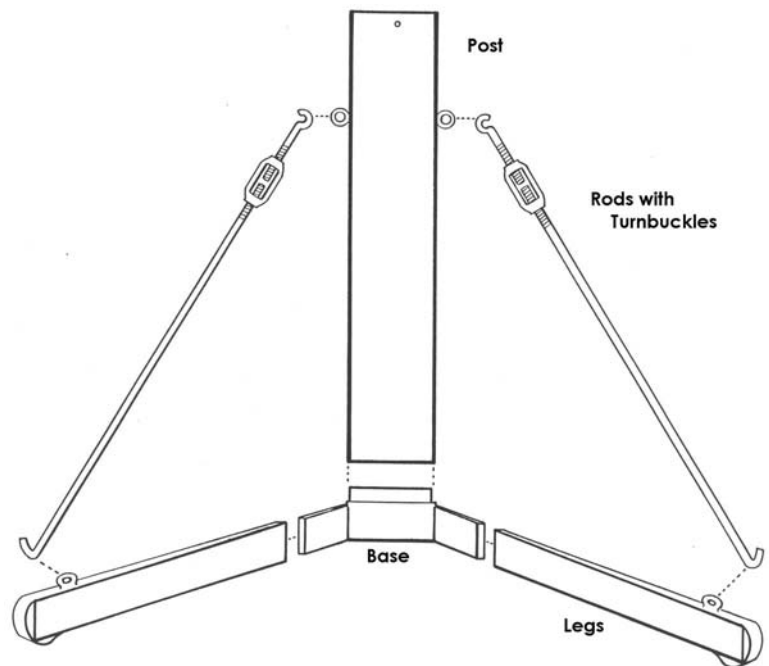

ASSEMBLE POLAR AXIS ASSEMBLY TO PIER

In order to track the motion of astronomical objects, the polar axis must be positioned so that an imaginary line drawn through the center of the axis points toward the celestial pole. At this stage of the assembly process, you want to position the mount so that it points roughly north.

1. Remove the four hand knobs on the pier top adapter and keep them close at hand.
2. Prior to lifting the polar axis assembly into place, turn the fine azimuth adjustment knobs so that the space between them is wide enough to allow the center azimuth block to fit easily between them. Ensure both pier top and polar axis assembly mating surfaces are clean and free of dirt.
3. Place the polar axis assembly onto the pier so that the center azimuth block fits between the fine azimuth adjustment knobs.
4. Move the base of the polar axis assembly so that the threaded holes of the pier top can be seen through each of the four slots.
5. Thread the four hand knobs loosely in place (you will tighten these later after polar alignment).

FITTING RIGHT ASCENSION ENCODER HOUSING

Since the polar alignment telescope and R.A. encoder adapter thread into the same location, you will need to switch back and forth between them as needed. This is good time to familiarize yourself with the removal and replacement of the R.A. encoder housing and encoder adapter.

If you use the JMI NGCMAX or MiniMAX Digital Setting Circles, you can use the “polar align” mode in these units instead of a polar alignment finder scope. Please continue to read these directions anyway since you may need to remove and reinstall the encoders if you use a polar alignment scope. The 900 is always supplied with the encoders installed.

1. To remove: Unscrew R.A. encoder housing and R.A. encoder adapter.
2. To replace: Thread the R.A. encoder adapter into the end of your R.A. axis. If your polar alignment scope is fitted, you must remove it first. Use only moderate hand pressure to tighten the R.A. adapter since you will need to remove it again.
3. If you look at the black encoder housing, you will see the black encoder itself mounted at the rear of the housing. When this installation procedure is complete, the encoder shaft will insert into the center hole of the R.A. encoder adapter. This allows the encoder to read the motion of the R.A. shaft as the right ascension moves.
4. Now thread the R.A. encoder housing onto the R.A. axis housing. You may need to wiggle the encoder housing gently to engage the shaft of the encoder (located within the R.A. axis housing) with the hole in the center of the R.A. encoder adapter. Again, use moderate hand pressure, as you will need to remove this again.

The hardware for your encoders is now installed. For actual set-up procedures for the “MicroMAX,” “MiniMAX” or “NGCMAX” digital computers, refer to the relevant operating manual.

If you remove the R.A. encoder frequently, you may wish to use a very tiny amount of auto grease on the mating threads.

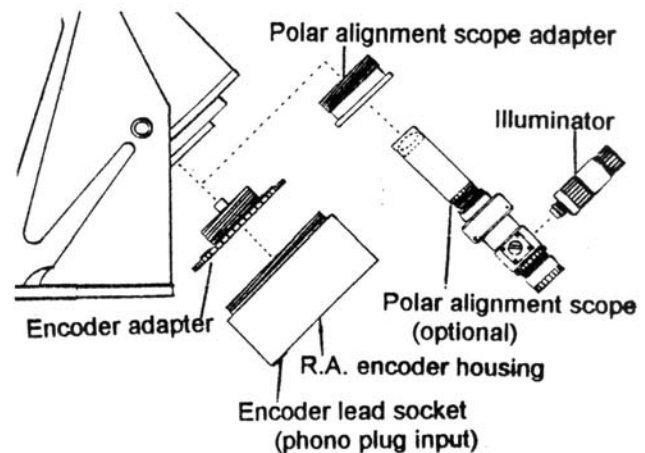

ALTITUDE AND AZIMUTH ADJUSTMENTS – ROUGH POLAR ALIGNMENT (for casual observation)

Follow these instructions if you want to roughly polar align your mount. If not, you may skip this section and move on to *Assemble Declination and Right Ascension Axes*.

You may polar align your mount with the telescope and counterweights attached. This is important for accurate polar alignment. However, the adjustment will require considerably more hand effort. So for rough polar alignment, you may wish to leave your scope and counterweights off.

For rough polar alignment, your goal is to sight the celestial pole when looking through the polar alignment sight hole in the center of the polar axis. You will need to make altitude (up/down) and azimuth (side to side) adjustments to the position of the mount.

1. Remove the R.A. encoder housing and encoder adapter as described in the previous section.
2. If you examine the polar axis assembly, you will see that the center of the R.A. shaft is hollow. The end of the R.A. axis is threaded to accept the polar axis telescope used for polar alignment. You do not need the polar alignment scope for this part of the process. If you have not done so already, loosen (1/2 turn) the four pier knobs.

NOTE: If you have already attached the Dec. axis, remove the sight hole cover and rotate the internal Dec. shaft by moving the top of the Dec. axis (or the mounting plate if it is attached) to reveal the sight hole that has been drilled into it. Now, you can look through the shaft to the other side.

3. **Azimuth adjustments:** Move the entire pier or tripod east or west until the mount is oriented approximately towards the pole (an imaginary line drawn through the hollow shaft). Use the two fine azimuth adjustment knobs, one on each side of the mount, to make fine adjustments in azimuth. You must back off the opposing azimuth knob in order to move the other knob in that direction. Please refer to the diagram on page 3.

4. **Altitude (latitude) adjustments:** Loosen the altitude locking knobs. Move the polar axis up or down with the large altitude adjustment knob located in the front of the polar axis assembly. The Tommy bar can be positioned in any of the threaded holes located in the altitude adjustment knob. Use this bar to help you turn the knob. Please refer to the diagrams on page 3. We have found that using the turnbuckle on the north leg of our pier also can make fine altitude adjustments, if used.
5. Continue your azimuth and altitude adjustments until you can sight Polaris in the polar alignment sight hole. At this point, you have achieved rough polar alignment, which may be sufficient for most casual visual observations. When the R.A. motor is engaged, it will compensate for the rotation of the earth and keep the target object within the eyepiece field of view. Your target object will slowly drift since polar alignment at this stage is only approximate. However, you can make corrections with your hand controller, as we will discuss later.
6. Tighten the altitude locking knobs by hand.
7. Tighten the pier knobs firmly by hand.

ASSEMBLE DECLINATION AND RIGHT ASCENSION AXES

Do not have your telescope or counterweights connected to the Dec. axis assembly for either assembly or disassembly of the Dec. and R.A. axes.

1. Position the R.A. axis as shown in the upper diagram on the right, with the "guide" notch "A" at the top, opposite the altitude adjuster knob.
2. During shipment, the Dec. axis assembly lock knobs will be fully screwed into the Dec. axis assembly. For correct assembly, these lock knobs should be unscrewed at least 7 full turns and *no more* than 8.5 full turns. This is between 5/16" and 3/8" out from the "shipped" tightened position.

IMPORTANT: These lock knobs can be completely removed from the Dec. axis assembly with about 9.5 full turns out.

3. Position the Dec. axis above R.A. axis as shown in the lower diagram to the right. A light movement (wiggle) in the downward direction (arrow A) will help to correctly seat the principle dovetail(s) and parallel guides.
4. When both Dec. and R.A. assemblies are fully seated, hand tighten both Dec. lock knobs.
5. Thread the counterweight shaft into the Dec. axis.
6. Attach the cradle plate with the appropriate screws.
7. Remove the hand knob and safety washer from the base of the counterweight shaft. Add sufficient counterweights (10 or 18 lb. counterweights are available) to the declination shaft to balance the telescope you intend to use. Always use two hands to attach or move them on the shaft.
8. Reattach the hand knob and safety washer to the end of the declination shaft. This will help to prevent injury if someone accidentally loosens the counterweight knob.

NOTE: Firm tightening of the counterweight knob will not damage the surface of the counterweight shaft. The pin that tightens against the stainless counterweight shaft is constructed of brass. Likewise, a bronze sleeve that has been press fit into the center of the counterweight will prevent marring of the shaft as you move the counterweight up and down.

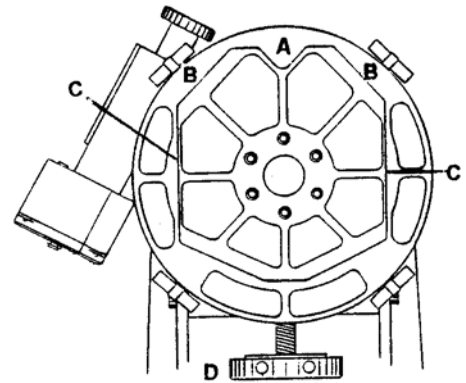

A - guide notch
 B - dovetails
 C - parallel guides
 D - altitude adjuster knob

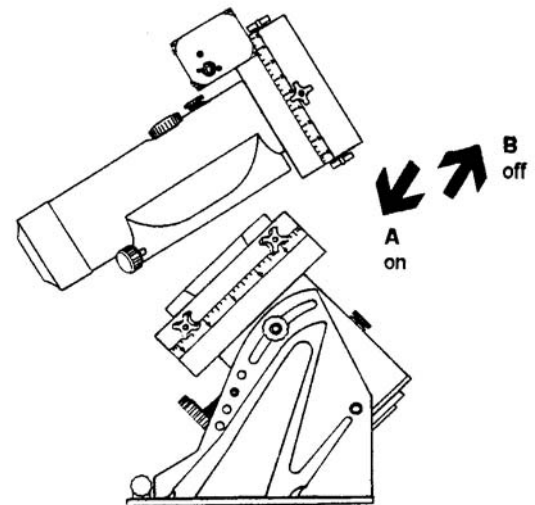

REMOVAL

1. Unscrew the lock knobs 5. 5 to 7 full turns (this is still 5/16" to 3/8" out from the fully tightened "shipped" position) and slide/tilt the Dec. axis assembly in an upwards direction (arrow "B")
2. For transport/storage we recommend fully tightening the lock knobs.

FINE POLAR ALIGNMENT – for astrophotography

Follow these instructions if you want to fine-tune the polar alignment of your mount. If not, you may skip this section and move to *Operation of the Mounting*.

1. Methods for fine polar alignment:
 - Polar alignment telescope – The north celestial pole can be viewed through the polar axis with the optional polar axis telescope. Please read the instruction sheets "Polar Axis Telescope and Illuminator."
 - JMI Digital Setting Circles – Please read the instructions included with your JMI unit.
 - Star Drift method – This is the most accurate method of polar alignment, however it is also the most time consuming. If you are planning long exposure astrophotos, we suggest that you use either the polar axis telescope or JMI digital setting circles, then tweak the final polar alignment by star drifting. Please refer to the recommended reading list at the end of this manual for sources that describe the star drift method.
2. Loosen the two altitude locking knobs and the four pier knobs and refer back to the section on *Altitude and Azimuth Adjustments – Rough Polar Alignment*. Do not loosen the polar axis pivot screws.
3. Follow one of the methods of polar alignment mentioned above.
4. When polar alignment has been achieved, tighten the two altitude locking knobs by hand. Please note that the polar axis pivot screws should have been tight throughout the fine polar alignment process.

OPERATION OF THE MOUNTING

R.A. and Dec. Damper knobs

The R.A. and Dec. damper knobs are not intended as axis locks. They should be tightened with moderate finger pressure so that a slight resistance can be felt when pushing an unclutched axis by hand. This really adds to the "feel" at the end of the scope with the drives adjusted correctly.

R.A. and Dec. Clutch knobs

1. What do they do?

The four R.A. and four Dec. clutch knobs depicted in the diagram on page 2 have the function of connecting the R.A. and Dec. axes to their respective drive worm wheel gears. Their function is progressive, from no tension (axes free to move – as required during correct balancing of the telescope) to a completely "locked up" state.

2. How can you find out what they really do?

As shipped, all 900 mounts have all four R.A. and Dec. clutch knobs firmly hand tightened. This will give you a good idea of the maximum tightness (clutch action) that can be achieved by hand effort alone. At this point, you must bear in mind that for optimum performance all four clutch knobs on each axis (R.A. or Dec.) should be tightened evenly with the same tension i.e. all four half tight, all four fully tight, etc.

In order to feel the effect of the clutch knobs, you may wish to partially assemble your mount. Fit together the R.A. and Dec. assemblies plus mounting plate and counterweight shaft. Do not put scope and counterweights on at this stage. With the above assembly (with the clutch knobs firmly hand tightened – "as shipped"), you can feel the amount of force needed to move each axis by hand. Grab each end of the telescope mounting plate and move it with a backward and forward movement of the Dec. axis. You will feel considerable resistance to this motion. Perform the same operation on the R.A. axis by moving the counterweight shaft backward and forward. With a well-balanced telescope, the above tightness of the clutch knobs will be sufficient for all normal conditions of use.

Now, if you proceed to mount up and balance your telescope, you can “feel” what this resistance in R.A. and Dec. (movement backwards and forwards) is like when you make these motions from the eyepiece end of your telescope as you would during normal use when slewing (pushing) by hand to acquire an astronomical object within the field of view of your finder or scope

3. How tight can the clutch be and can you do any damage by pushing against them?

The maximum tightness of this clutch system is $\frac{1}{2}$ turn (with a 5/32 allen key) further in than the tension you can achieve with the knobs by hand. You will see that each clutch knob has a 5/32 hex socket for tightening with an allen key. With this extra $\frac{1}{2}$ turn on each clutch knob, the axis (axes) will be considered completely “locked up.” You should not attempt to push your scope by hand against this “locked up” resistance, or undue stress will be placed on the worm wheel/worm and bearings.

However, if you are undertaking a very long astrophoto exposure, it is advisable to increase the pressure on each clutch knob (with the 5/32 key) by about $\frac{1}{4}$ th turn on Dec. and $\frac{1}{8}$ th turn on R.A. You may safely slew the scope by hand with this tension; however, you will notice considerably more effort is required to achieve movement.

This is the absolute maximum tension that can be used for hand slewing. As a general rule, if you have a big scope (7” or 8” refractor) with all the accessories, you will need more clutch tension than a 5” or 6” scope.

Drive Test Knobs - You will notice in the diagram below the R.A. and Dec. drive test handles. These are NOT intended as manual control knobs for centering objects in the field of view. Please use the buttons of the dual axis hand controller to center objects in the eyepiece. Never, never attempt to turn these knobs manually.

These test knobs are used at the factory for initial setting of the worm wheel/worm mesh. Their main purpose for the end user is to give a quick visual verification of the worm drive motion (forward, reverse at 2x, 8x, and 16x). You can easily see the rotation of these test knobs especially at 8x and 16x speeds.

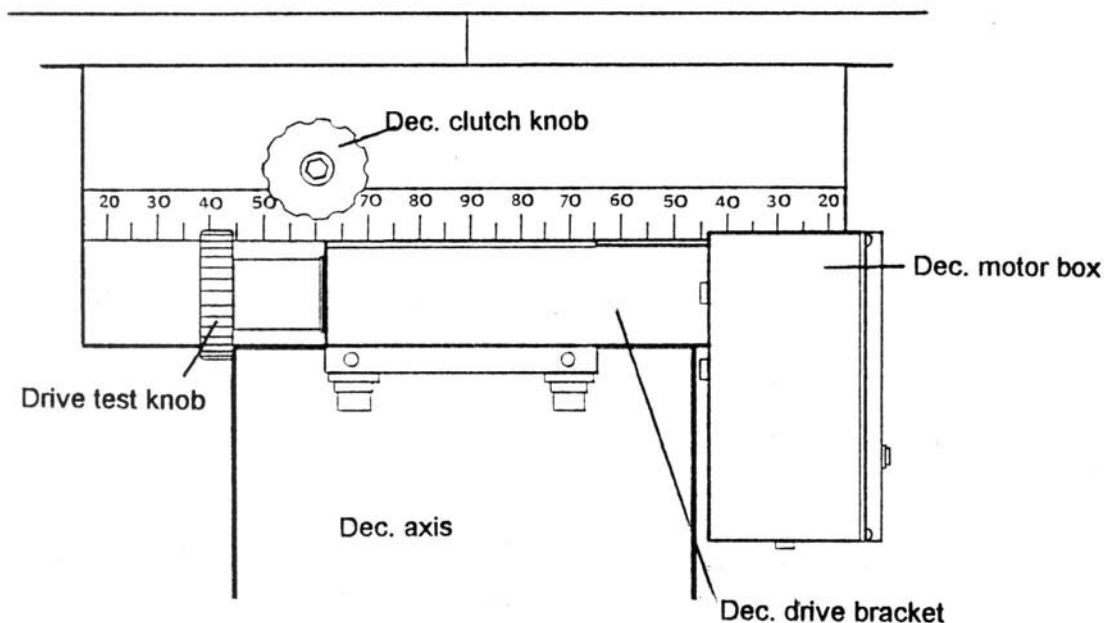

Balancing Your Telescope: For proper operation, the telescope must be adequately counterbalanced. Start by balancing the tube assembly.

1. Tighten the four R.A. axis clutch knobs.
2. Loosen the four Dec. axis clutch knobs (about $\frac{3}{4}$ to 1 turn) so that the telescope moves freely about the declination axis. Be careful, because if your telescope is significantly out of balance, it may swing rapidly in the out of balance direction.
3. Position the R.A. axis so that the counterweights are in their “lowest” position, i.e., the declination axis assembly is in the meridian. This is the usual way that German equatorial are depicted, as in the diagram on page 2.

4. Loosen the tube mounting rings and slide the tube up and down for balancing. This is best done with the tube in the horizontal position.
5. The scope is balanced when it stays put (does not move) with the clutches loose and movement back and forth about the declination axis has the same feel in both directions.
6. Now tighten the declination axis clutch knobs and position the telescope horizontally and the declination axis horizontally. The center of the counterweights is now the same height as the middle of the tube.
7. Loosen the R.A. clutch knobs. Again exercise caution, because if your scope is significantly out of balance it may swing rapidly in the out of balance direction.
8. Move the counterweight(s) up or down to achieve balance in R.A. Again, movement back and forth about the R.A. axis should have the same feel in both directions.
9. Try to anticipate any balance problems due to the extra weight of diagonals, heavy eyepieces, finders, solar filters, etc. If the scope moves by itself, when the clutches are loose, then the scope is not fully counterbalanced adequately. A small amount of imbalance is permissible and even desirable for astrophotography and imaging. When the mount is properly polar aligned, it is possible to take unguided astrophotos for several minutes without trailed star images.

OPERATION OF THE CONTROLLER

The push button controller contains all the circuitry for driving the two motors. The controller will be operational when attached to both the motor of the mount and a power source. There is no on-off switch.

A very accurate quartz clock specifically calibrated for the drive gear is an integral part of the controller. The calibration is made to the King sidereal rate which compensates for atmospheric refraction over a large part of the sky. With this tracking rate, it is easier to maintain critical guiding at high power. For the most sophisticated tracking of celestial objects, the controller has a built-in provision for attaching an ST-4 or ST-6 CCD imaging camera/autoguider. Using the autoguider function, it is possible to take long exposure astrophotos totally unattended. You can walk away from the setup to enjoy other observing activities while your astrograph is in operation.

CABLES: Place the DC power cord into the phono plug outlet of the R.A. motor box. Plug the short length of the "Y" cable into the R.A. motor box and the long length into the Dec. motor box. Complete the cable assembly by joining the control box cable to the "Y" cable. The control box and motors are designed to work at 12 volts DC. Suggested power sources include: portable rechargeable battery pack, auto battery, or power inverter for 110 volts with a minimum output of 800ma.

DRIVE ROTATION: If you are operating the 900 mount north of the equator, the HEM (hemisphere) switch must be set to "N". If south of the equator set the switch to "S".

PUSH BUTTONS: The four red buttons are arranged so that the left and right buttons control the movement in right ascension, and the top and bottom buttons control the declination. This is the normal orientation of objects in the eyepiece field. If the star moves down when you push the "N" button, move the DEC REVERSE switch into the opposite position. Pushing the right hand button "E" should cause the star to move to the right. If it moves to the left, move the R.A. REVERSE switch to the other position. When properly set up, the controller buttons will cause the object to move according to your orientation at the eyepiece.

MODE SWITCH: There are three guiding modes (rates): a 2x guiding rate and a 8x and 16x slew rate. The slew rates are for positioning objects in the field, the guide rate is for fine guiding at high powers during astrophotography. Move the switch to select the mode that you prefer.

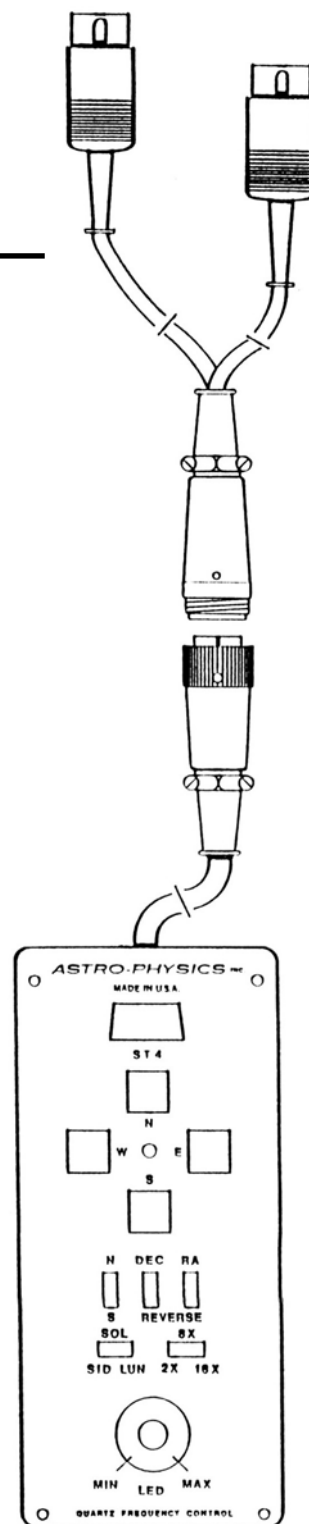

SELECT BUTTON: The control box has three drive rates to choose from: SID (sidereal), SOL (solar), and LUN (lunar). Select the position appropriate for the object under observation.

King Sidereal: Tracking rate for observing planets, stars, galaxies, and other distant objects.
Solar: Tracking rate for observing the sun.
Lunar: Tracking rate for observing the moon.

LED KNOB: There is an LED output available on the 900 Dec. axis motor housing as shown on the diagram on page 2. You may insert your LED reticle to this plug. Brightness can then be controlled using the MIN to MAX (minimum to maximum) setting of the LED knob.

AUTOGUIDER CONNECTION: If you own a Santa Barbara Instrument Group (SBIG) ST-4 or ST-6 Star Tracker/Imaging system, connect it to the controller via this 9 PIN connector. Call Astro-Physics to purchase a separate cable for this connection or we can add the correct connector to the cable supplied by SBIG.

GUIDING YOUR ASTROPHOTOS

The natural tendency of astrophotographers is to push the directional button of the controller in the direction he or she wants the guide star to move until the star has centered itself in the guiding reticle. This method often results in overshooting the center of the reticle since the reaction time to let go of the button is often too late. By the time the gears in the drive motor have reversed and are driving again at the normal guiding rate, the star has moved past the center of the reticle. Then the opposite button is pushed to move the guide star back in the opposite direction toward the center and the same overshooting may occur.

The proper way to guide (and this will apply to almost any commercially available mounting) is to pulse your correction, much as the SBIG ST-4 does in its auto-guiding operation. Pulse the button for only a fraction of a second and note the new position of the guide star. If it has not moved far enough, pulse it again. Normally, it takes only one or two pulses to re-center the star in declination, since this drift will be extremely slow (assuming the mount was properly polar aligned). When the star needs to be reversed, it rarely takes more than 5 to 8 pulses in rapid succession, each lasting less than 1/10 second to get the star to re-center in the reticle. This same method should be used to keep the star centered in right ascension also. With some practice, you will be able to keep the guide star centered perfectly in declination with only an occasional pulse every 5 or 10 minutes while concentrating almost entirely on the right ascension drift.

(Proceed to next page for *Mount Maintenance and Alignment*)

MOUNT MAINTENANCE AND ALIGNMENT

Under normal operating conditions, minimal maintenance is required. Every 12 months, the clutch knobs (4 for Dec. and 4 for R.A.) should be removed, and one or two drops of light oil (3-in-1 household oil) should be put in the exposed hole. If the R.A. and Dec. axes are bolted together for a long time in outside conditions, i.e., in a permanent observatory, then the mating surfaces should be lightly oiled or greased – if you expect to get them apart again after 10 years.

Your 900 is a precision instrument with very accurate worm and wheel adjustments. Please be careful if you place the mount on a flat surface, i.e. the ground or trunk of your car. The gear alignment may be affected if the R.A. and Dec. motor/gear box assemblies sustain undue lateral force. This is true of any fine instrument. We suggest that you transport and store the mount in a case or in a well-padded box

NOTE: If your battery runs low, the declination motors will stop first, through the R.A. will continue to drive until the power is drained.

If any problems occur, please don't hesitate to contact Astro-Physics for assistance.

ASTRO-PHYSICS INC
11250 Forest Hills Road
Rockford, IL 61115
Telephone: (815) 282-1513
Fax: (815) 282-9847
www.astro-physics.com

Recommended reading list from our staff:

The Backyard Astronomer's Guide, Terence Dickinson and Alan Dyer, Camden House Publishing, 1991. The authors, both former editors of *Astronomy* magazine, offer practical insight into astronomical equipment, finding your way around the sky, polar alignment, using setting circles, and astrophotography. This book provides excellent explanations and is well organized and illustrated.

All About Telescopes, Sam Brown, Edmund Scientific Company, 1975. This has excellent information regarding the principles of mount construction and operation, using setting circles, eyepiece projection, etc. Illustrations and formulas galore. Many of the instruments pictured are outdated, however the underlying principles are timeless.

Norton's 2000.0 Star Atlas and Reference Handbook, edited by Ian Ridpath, J. Wiley Publishers, 1989. Star maps, information regarding polar alignment of German equatorials and observing techniques.

08-07-95