

# ASTRO-PHYSICS

## 600E GERMAN EQUATORIAL MOUNT (600HDA) WITH DUAL AXIS STEPPER MOTORS AND 8010 CONTROLLER

### MODEL 600HDA (600E) PARTS LIST

- 1pc. 600E HDA Equatorial Head with stepper motors on right ascension and declination axes, 600E silver version
- 1pc. Cradle Plate
- 1pc. Stainless counterweight shaft with washer stop and black plastic knob (5/16-18 threaded rod)
- 1pc. Dual axis controller, model number 8010
- 1pc. Power cord (cigarette lighter adapter)
- 2pcs. Interconnect cords (connect hand controller to the motors)
- 3pcs. Black plastic knobs with 1/4-20 threaded rod
- 4pcs. 1/4-20x5/8" socket cap screws for cradle plate
- 1pc. 3/8" long arm Allen wrench
- 1pc. 3/16" short arm Allen wrench
- 2pcs. Red Caplugs
- 1pc. Velcro (to attach hand controller to surface of your choice)

### ASSEMBLY INSTRUCTIONS FOR MODEL 600HDA (600E)

Please read all instructions before attempting to set up your 600HDA mount. The model 600HDA is very rugged; however, like any precision instrument, it can be damaged by improper use and handling. Please refer to diagram 1.

The following terms and abbreviations are used interchangeably in these instructions:

- polar axis = right ascension axis = R.A. axis
- declination axis = Dec. axis

### ASSEMBLE PIER OR TRIPOD

Begin by assembling the pier or tripod at the desired observing location.

*PIER:* Slide the three legs onto the nubs of the base, orienting one leg to the north. Place pier post on the base and attach the tension rods. The turnbuckles should be drawn tight until the whole assembly is stiff enough to support your weight without movement. Please refer to diagram 2.

*ADJUSTABLE HARDWOOD TRIPOD:* Remove the tripod from its carrying bag and attach the shelf to each of the three legs with the knobs provided. Adjust legs to the desired height and spread. Lock in position with the hand knobs. Be sure that the adapter plate for the 600HDA has been installed on your tripod. Please refer to diagram 3.

### ASSEMBLE MOUNTING TO PIER

In order to track the motion of astronomical objects, the polar axis must be positioned so that an imaginary line drawn through the hollow shaft points toward Polaris. At this stage of the assembly process, you want to position the mount so that it points roughly north. Place the mount into the top of the pier or tripod so that the threaded R.A. axis hole is on the south side of the pier (opposite the pier leg that you oriented north). Align the holes of the mount and pier. Screw in the three hand knobs to hold the mount in place.

### ALTITUDE AND AXIMUTH ADJUSTMENTS

Follow these instructions if you want to rough polar align your mount. If not, you may skip this section and move onto "Assemble Cradle Plate and Counterweight Shaft." You may make these adjustments with the telescope mounted or not, according to your preference. If you plan to mount your scope at this stage, refer to the "Assemble Cradle Plate and Counterweight Shaft" section first.

1. If you examine the polar axis assembly, you will see that the center of the polar shaft is hollow. You may need to rotate the internal Dec. shaft by moving the top of the Dec. axis (or the cradle plate if it is attached) to align the sight hole that has been drilled into it. Now you can look through the shaft to the other side. The end of the R.A. axis is threaded to accept the optional polar axis telescope used for polar alignment.
2. Loosen the two ½-13 socket head bolts on each side of the mount using the 3/8" hex key provided. Use the 3/16" hex key to loosen the ¼-20 socket head cap screw on each side of the mount base.
3. Move the polar axis up or down and the entire pier east or west until Polaris is visible through the hollow shaft of the polar axis.
4. Fine azimuth adjustments: With the mount now oriented approximately towards the pole, use the two small black knobs on each side of the mount to make fine adjustments in azimuth. You must back off the opposing azimuth knob in order to move the other knob in that direction.
5. Fine altitude adjustments: These adjustments are made with the large black knob moving the polar axis up and down. We have found that fine altitude alignment can be made also by using the turnbuckle on the north leg of the pier.
6. At this point, you have achieved rough polar alignment, which may be sufficient for most casual visual observations. When the R.A. motor is engaged, it will compensate for the rotation of the earth and keep the target object within the eyepiece field of view. Your target object will slowly drift since polar alignment at this stage is only approximate. However, you can make corrections with your hand controller, as we will discuss later.
7. If rough polar alignment is sufficient, snug the two ½-13 screws and two 1/3-20 screws to lock the mount into position.

## **POLAR ALIGNMENT**

Follow these instructions if you want to fine-tune the polar alignment of your mount. If not, you may skip this section and move onto "Assemble Cradle Plate and Counterweight Shaft".

1. Polar alignment telescope – The pole can be viewed through the polar axis with our optional polar alignment telescope. Please read the instructions that were included with the polar axis telescope.
2. If you don't have a polar alignment telescope, you may use the star drift method.
3. When the proper alignment has been achieved, snug the two ½-13 screws and two ¼-20 screws lightly to secure the polar axis and recheck alignment. If no movement has occurred, finish tightening the two bolts as much as possible to prevent movement when the telescope and counterweights are attached.

**IMPORTANT:** Failure to tighten the side bolts can cause the axis to slip, with resultant damage to the mount.

## **ASSEMBLE CRADLE PLATE AND COUNTERWEIGHT SHAFT**

1. Attach the cradle plate to the Dec. axis with the four ¼-20 x 5/8" screws provided. The cradle plate should not cover the Dec. clutch knob. Screw the counterweight shaft to the Dec. axis. Please refer to diagram 4.

**NOTE:** During disassembly, the cradle plate may remain attached to the declination axis or be removed as desired.

**IMPORTANT:** Always attach the counterweights before mounting the telescope to prevent sudden movement of an unbalanced tube assembly, which may cause damage or injury. Remember that the counterweights are heavy and will hurt if they fall on your toe.

2. Remove the hand knob and washer from the base of the counterweight shaft. Add sufficient counterweights to the counterweight shaft to balance the telescope you intend to use. Always use two hands to attach or move them on the shaft. Reattach the hand knob and washer to the end of the counterweight shaft. This will help to prevent injury if someone accidentally loosens the counterweight hand knob.

**NOTE:** A firm tightening of the counterweight knob will not damage the surface of the counterweight shaft. The pin that tightens against the stainless counterweight shaft is constructed of brass. Likewise, the bronze sleeve that has been press fit into the center of the counterweight will prevent marring of the shaft as you move the counterweight up and down.

## OPERATION OF THE MOUNTING

The mounting has a set of clutches on both axes.

**RIGHT ASCENSION AXIS CLUTCH:** The knob on the top of the polar axis is the clutch for that axis. The R.A. motor will not drive the R.A. axis unless it is engaged. Avoid excessive pressure when tightening the knob.

**DECLINATION AXIS CLUTCH:** The knob just below the cradle plate is the clutch for the Dec. axis. The Dec. motor will not drive the Dec. axis unless it is engaged. Avoid excessive pressure when tightening the knob.

For proper operation, the telescope must be adequately counterbalanced. Start by balancing the tube assembly. Tighten the R.A. clutch knob and loosen the declination axis knob so that the telescope tube rotates on the declination axis. Slide the tube up or down in the cradle rings until it stays put with no clutch drag. Now, tighten the declination axis and loosen the R.A. clutch knob. Move the counterweights up or down to achieve balance in R.A. Remember to allow for the extra weight of diagonals, eyepieces and finder scopes. If the scope moves by itself, even when the clutches are loose, the scope is not counterbalanced properly. Note that a small amount of imbalance on the East side of the mount is permissible and even desirable for astrophotography and imaging.

**DRIVE ROTATION:** If you are operating the 600HDA north of the equator, the HEMISPHERE switch must be set to "N". If south of the equator set the switch to "S".

## OPERATION OF THE 8010 CONTROLLER

The push button controller contains all the circuitry for the two motors. Please refer to diagram 5.

**POWER CORD:** Attach the 3-pin power cord to the mount and plug the other end into your car's cigarette lighter or into a 12-volt portable battery pack. Plug the R.A. control cable into the controller's right-hand jack (as seen from above). Plug the Dec. cable into the left-hand jack. No damage will result from reversing the cables; the controller simply will not operate. With the cables in place, one of the lamps will light to indicate operation. It is not necessary to attach the Dec. cable to the controller to run the R.A. axis.

**PUSH BUTTONS:** The four red buttons are arranged so that the left and right buttons control the right ascension, and top and bottom buttons control the declination. This is the normal orientation of objects in the eyepiece. The buttons may be used to move an object to the desired location in the field, or to keep a guide star on a crosshair by making tiny guiding corrections.

Pushing the upper button will cause the object to move "up" in the eyepiece field. If the star moves down when you push the "up" button, move the DEC switch into the other position. Pushing the right-hand button will cause the star to move to the right. If it moves to the left, move the RA switch to the other position. When properly set up, the controller buttons will cause the object to move according to your commands.

**MODE SWITCH:** There are two guiding modes (rates): 2x guide and 8x slew rates. The slew rate is for positioning objects in the field, the guide rate is for fine-guiding at high powers during astrophotography. Move the switch to select the mode that you prefer.

**SELECT BUTTON:** The controller has a select button with four LED indicators that allow you to choose the driving rate. Three of them are internally set for SID (sidereal), SOL (solar) and LUN (lunar). The VAR (variable) is adjustable with the right hand knob. When you push the SELECT button, one of the LEDs will light up, indicating your selection. Push the button again and the LED to the left will light. When you begin each observing session, the LED for solar rate will light up. We chose solar as the default because it is more difficult to read the LEDs in sunlight.

**VAR. RATE KNOB:** When the VAR LED light is lit, you may turn this knob to vary the drive rate of the motors. This is very useful for tracking planets and comets.

**LED KNOB:** There is an LED output available on the 600HDA. The output is located on the declination axis housing (marked RETICLE OUT). You may insert your illuminated LED reticle to this plug. Brightness is controlled with the left hand knob on the controller labeled LED.

## **MOUNT MAINTENANCE AND ALIGNMENT**

Under normal operating conditions, no maintenance is required. Your 600HDA is a precision instrument with very accurate worm and wheel adjustments. Please be careful if you place the mount on a flat surface, i.e. the ground or trunk of your car. The gear alignment may be affected if the R.A. and Dec. motor/gear box assemblies sustain undue lateral force. This is true of any fine instrument. We suggest that you transport and store the mount in a case or in a well-padded box

**NOTE:** If your battery runs low, the declination motors will stop first, though the R.A. will continue to drive until the power is drained.

## **POSSIBLE UPGRADES FOR YOUR 600HDA (600E)**

**Additional Mounting Plate Options:** Please refer to our website to learn of additional mounting plate options. All models of the 600E can use the same plates.

**Encoders for Digital Setting Circles:** The declination axis of the 600HDA must be modified in order to use the encoders (part #ENC600). Please call Astro-Physics for information about # 6ENMOD modification.

**ST-4 Modification:** The 8010 controller can be modified to accept an autoguider (i.e. SBIG ST-4). If this modification has already been made, you will see an on-off switch and male 15-pin D-sub connector on the lower side of the box. Please call Astro-Physics if you need modification # ST4MOD.

If any problems occur, please don't hesitate to contact Astro-Physics for assistance.

ASTRO-PHYSICS, INC  
11250 Forest Hills Road  
Rockford, IL 61115  
Telephone: (815) 282-1513  
Fax: (815) 282-9847  
[www.astro-physics.com](http://www.astro-physics.com)

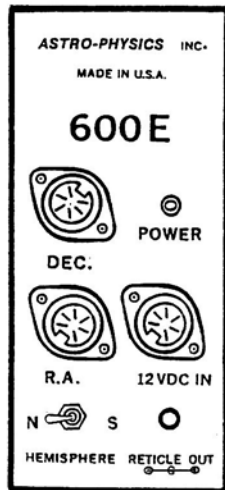
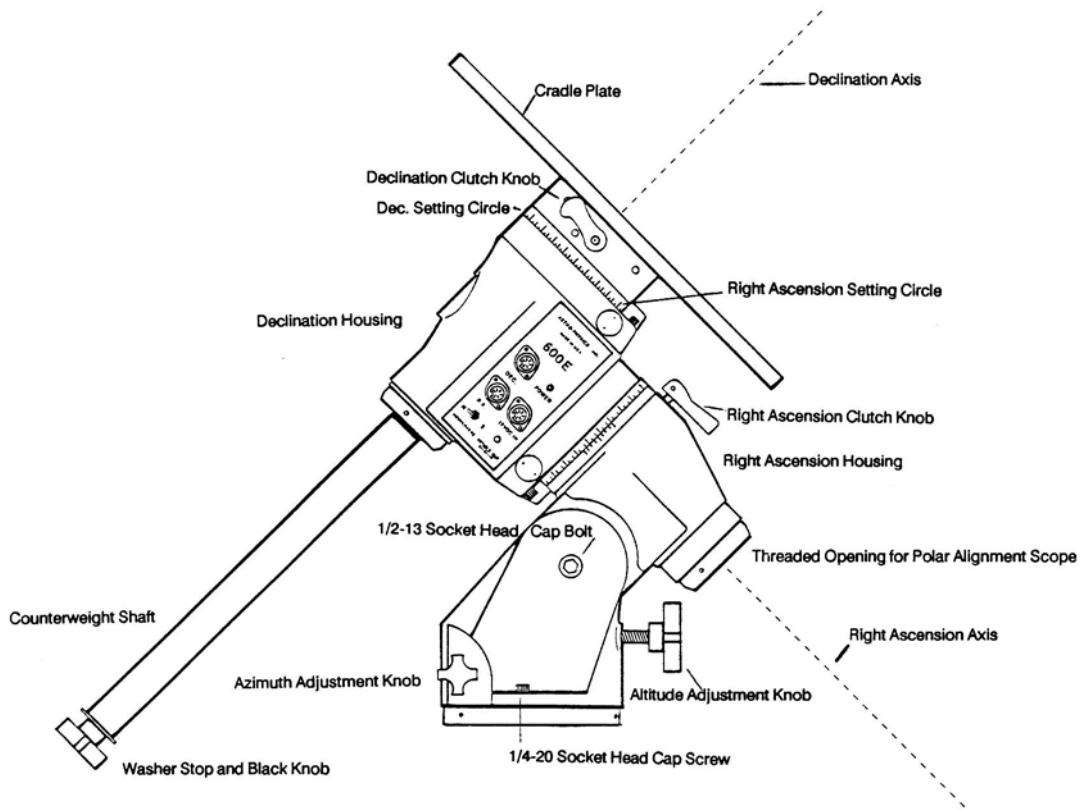

Diagram 1 - 600 E Parts Illustration

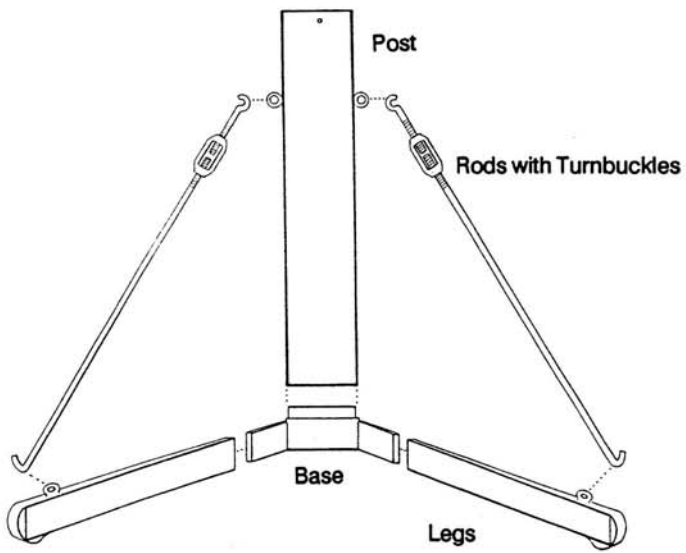

Diagram 2 - Pier Assembly

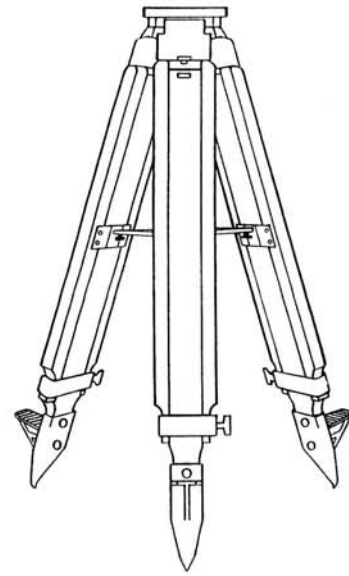

Diagram 3 - Birch Tripod Assembly

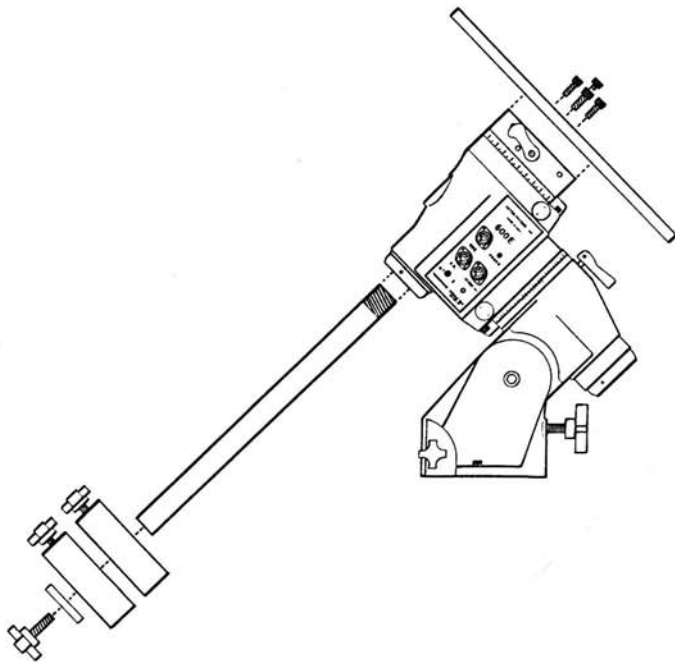

Diagram 4 - Assembly of 600 E Components

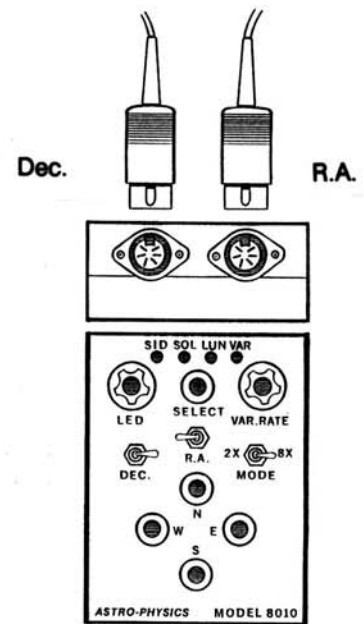

Diagram 5 - Model 8010 Hand Controller

## INSTALLATION OF ENCODERS AND ENCODER HOUSINGS 600E MOUNT

**Encoders for Digital Setting Circles:** If the declination axis of the 600HDA is modified it can be used with the encoders (part #ENC600). Please call Astro-Physics for information on how you can tell if your mount is already modified.

### PARTS LIST

- 1 Right ascension (R.A.) Encoder housing (black anodize, with 3 thumbscrews)
- 1 Declination (Dec.) Encoder housing (black anodize)
- 1 R.A. Axis Adapter (clear anodized, silver), labeled R.A.
- 1 Dec. Axis Adapter (clear anodized, silver), labeled Dec.

To install your encoders, first remove your telescope from your mount. Remove your declination counter weight(s) *and* declination shaft.

### FITTING DECLINATION ENCODER HOUSING

**NOTE:** Please note that the panel in the image of the 600E declination axis below is from a different version of the 600E, but the instructions for the encoder assembly are the same.

1. If the encoders were purchased with the 600E mount, it is likely that the declination axis adapter and encoder housing have already been installed. No further action will be required, as this encoder will remain in place.
2. If the encoders were purchased separately, the silver-colored Dec. axis adapter may be inside the black Dec. axis encoder housing. If it is, remove it now by grasping and pulling it out.
3. Thread the Dec. axis adapter into the end of your Dec. axis (from where you earlier removed the Dec. counterweight shaft). Final tightening should be done with firm hand pressure. Normally the Dec. axis adapter will not be removed.
4. If you look into the black encoder housing, you will see the encoder itself mounted at the rear of the housing. When this installation procedure is complete, the encoder shaft will insert into the center hole of the Dec. axis adapter. This allows the encoder to read the motion of the declination shaft as the declination axis moves.
5. Thread the Dec. encoder housing onto the Dec. axis housing of the 600E mount. You may need to wiggle the encoder housing gently to engage the shaft of the encoder with the hole in the center of the Dec. axis adapter. When the threading is complete, tighten up with firm hand pressure since normally this encoder housing will not be removed.
6. The counterweight shaft may now be rethreaded into the rear of the Dec. encoder housing.

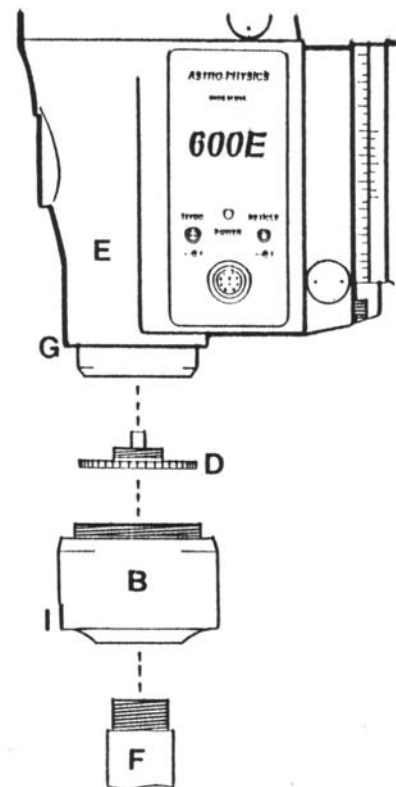

600E Mount Dec. Encoder Assembly

- B Declination (Dec.) encoder housing (encoder mounted inside)
- D Declination axis adapter
- E Declination axis housing of 600E mount
- F Declination counterweight shaft
- G Location to thread in encoder housing
- I Encoder lead socket (phone plug input)

## FITTING RIGHT ASCENSION ENCODER HOUSING

1. Whether you purchased the encoders with the mount or as a later option, it is likely that you will need to install this encoder. The silver-colored R.A. axis adapter may be inside the R.A. axis encoder housing. If it is, remove it now by grasping and pulling it out.
2. Thread the R.A. axis adapter into the end of your R.A. axis. If your polar alignment scope is already there, you must remove it first. Use moderate hand pressure to tighten the R.A. adapter since you may need to remove it to install the polar axis telescope at a later time.
3. If you look into the black encoder housing, you will see the encoder itself mounted at the rear of the housing. When this installation procedure is complete, the encoder shaft will insert into the center hole of the R.A. axis adapter. This allows the encoder to read the motion of the R.A. shaft as the right ascension axis moves.
4. Now carefully slip the R.A. encoder housing onto the R.A. axis housing. You may need to wiggle the encoder housing gently to engage the shaft of the encoder (located within the R.A. axis housing) with the hole in the center of the R.A. axis adapter. Tighten the three thumbscrews evenly to secure in place.
5. Since the polar axis telescope and R.A. axis adapter thread into the same location, you will need to switch back and forth between them as needed. If you use the JMI "NGC MAX" or "Mini MAX" Digital Setting Circles, you can use the "polar align" mode in these units instead of a polar axis finder scope!

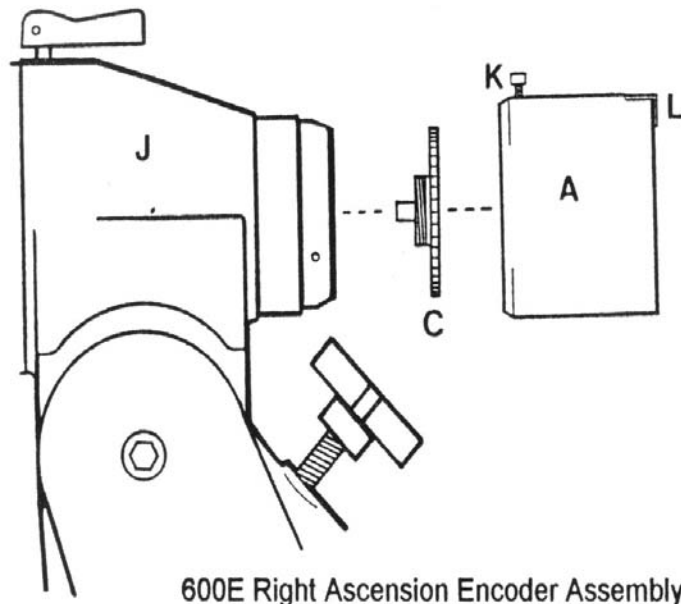

- |   |   |
|---|---|
| A | Right ascension (R.A.) encoder housing (encoder mounted inside) |
| C | Right ascension axis adapter                                    |
| J | Right ascension axis housing                                    |
| K | Thumbscrew  |
| L | Encoder lead socket (phone plug input)                          |

The hardware for your encoders is now installed. For actual set-up procedures for "Micro MAX", "Mini MAX" or "NGC MAX" digital readouts, refer to the relevant operating manual.

## PERIODIC MAINTENANCE

If you remove the R.A. encoder frequently, you may wish to use the very tiniest amount of auto grease on the mating threads.