

ASTRO-PHYSICS

1200 GERMAN EQUATORIAL WITH SMD SERVO MOTOR DRIVE

MODEL 1200SMD PARTS LIST	2
FEATURES AND SPECIFICATIONS	2
INTRODUCTION	3
Why Polar Alignment is Important	3
Compensation for the Earth's rotation	3
ASSEMBLY INSTRUCTIONS	4
Before You Leave Home	5
Gross Latitude Adjustment	5
Attach Pier Adapter to Pier Post	6
Assemble Pier (purchased separately)	6
Assemble Polar Axis Assembly to Pier or Tripod	6
Altitude and Azimuth Adjustments - Rough polar alignment	7
Assemble Declination Axis	7
Removing Declination Axis at the End of your Observing Session	8
Attach Mounting Plate (purchased separately)	9
Attach Mounting Rings (purchased separately)	10
Fine Polar Alignment	10
1200SMD Model - Methods for fine polar alignment	10
1200GTO Model - Methods for fine polar alignment	10
Altitude and Azimuth Adjustments	10
OPERATION OF THE MOUNTING	11
R.A. and Dec. Damper Knobs	11
R.A. and Dec. Clutch Knobs	11
Balancing Your Telescope	11
SERVO MOTOR DRIVE	12
MOUNT MAINTENANCE AND ALIGNMENT	12
INSTALLATION OF ENCODERS AND ENCODER HOUSINGS -1200 MOUNT	13
Fitting Declination Encoder Housing	13
Fitting Right Ascension Encoder Housing	14
Periodic Maintenance	14
POLAR ALIGNMENT TELESCOPE AND ILLUMINATOR	15
Polar Alignment Scope	15
Illuminator	15
Installation and Adjustments	16
Using your Polar Alignment Telescope	16
Remarks	17

ASTRO-PHYSICS

1200 GERMAN EQUATORIAL WITH SMD SERVO MOTOR DRIVE

MODEL 1200SMD PARTS LIST

- 1 Polar axis assembly (right ascension-R.A.) with Servo Box
- 1 Declination (Dec.) axis assembly
- 1 Pier top adapter with six (6) 5/16-18 x 5/8" button head screws with washers
(these may be attached to your pier post if you ordered one)
- 1 Stainless counterweight shaft with washer stop and black plastic knob (knob has 5/16 thread)
- 1 Polar Axis telescope adapter
- 1 RA cable – 13" long
- 1 Dec cable – 38.5" long
- 1 D.C. power cord (cigarette lighter adapter on one end) - 8' long
- 1 Servo Micro-Drive Controller
- 1 Hex key set

In order to fully assemble your mount, you will need the following items sold separately: mounting plate, 10" O.D. pier, counterweights, and portable rechargeable battery pack (or 110 to 12V DC converter). Several sizes and types are available for your selection. Many of these items will be discussed throughout these instructions.

Several additional options are available:

Santa Barbara Instrument Group CCD Imaging cameras and ST-4 Autoguider - if you plan to pursue CCD imaging or astrophotography

Pier accessory trays for 10" pier and support bars - handy to keep your eyepieces close at hand

Polar axis telescope - threads into the base of the polar axis assembly. This item is no longer available for purchase, however some users may have one already.

Mounted encoders - you will need these if you plan to use digital setting circles

JMI Digital setting circles

FEATURES AND SPECIFICATIONS

R.A. worm wheel:	10.3", 225 tooth aluminum	Azimuth adjustment:	Approximately 14 degrees
Dec worm wheel:	7.2", 225 tooth aluminum	Setting circles:	Porter Slip Ring design, engraved
Worm gear:	Brass	Right ascension:	4-minute increments, pointer
R.A. shaft:	3.35" diameter	Declination:	1-degree increments, pointer
R.A. thrust bearings:	9.5" diameter	Motors:	Zero-cogging servo motors
Dec shaft:	2.36" diameter	Power Consumption:	0.4 amps at the sidereal rate
Dec thrust bearings:	6.5" diameter	Power requirements:	12 VDC
Counterweight shaft:	1.875" diameter stainless steel, removable	Weight of mount:	total -94 lbs. Dec axis -30 lbs. R.A axis - 50 lbs. counterweight shaft -14 lbs.
Latitude range:	19 to 68 degrees with or without polar scope or encoders attached (if you are above 65° you will have to remove one pier top knob)		

INTRODUCTION

The 1200 German equatorial was designed to meet the needs of the advanced observer who requires a mount with maximum strength and rigidity and minimum weight. The excess material in both axes has been carved out while retaining a heavily ribbed structure for internal strength and rigidity. A unique dovetail was machined into the mating surfaces of the R.A. and Dec axes. This feature allows quick and easy assembly in the field without any tools.

The Servo Micro-drive controller is intended for those observers who enjoy searching for objects by star hopping and using star charts. These functions are included: selection of tracking and guiding or centering rates, PEM (permanent error memory), declination backlash control, RA/Dec reversal, adjustable brightness of the crosshair of your illuminated guiding eyepiece and movement of N-S-E-W directional keys.

The 1200 is equally at home in a permanent observatory or as a portable mounting for remote star parties thanks to the ease with which the two axes come apart. This is the perfect mount for a large refractor, Newtonian, Cassegrain or astrograph.

In order to maximize your pleasure on your first night out, we recommend that you familiarize yourself with the assembly and basic operation of the mount indoors. The temperature will be comfortable, the mosquitoes at bay, and you'll have enough light to see the illustrations and read the manual. Please take particular note of counterbalancing, use of the clutches and operation of the keypad controller.

Why Polar Alignment is Important

Compensation for the Earth's rotation

If you were to take a long exposure photograph with Polaris (often called the North Star) in the center of the field, you would discover that all stars seem to revolve around Polaris. This effect is due to the rotation of the earth on its axis. Motor driven equatorial mounts were designed to compensate for the earth's rotation by moving the telescope at the same rate and opposite to the earth's rotation. When the polar axis of the telescope is pointed at the celestial pole (polar aligned) as shown in [Diagram 1](#), the mount will follow (track) the motions of the sun, moon, planets and stars. As a result, the object that you are observing will appear motionless as you observe through the eyepiece or take astrophotos.

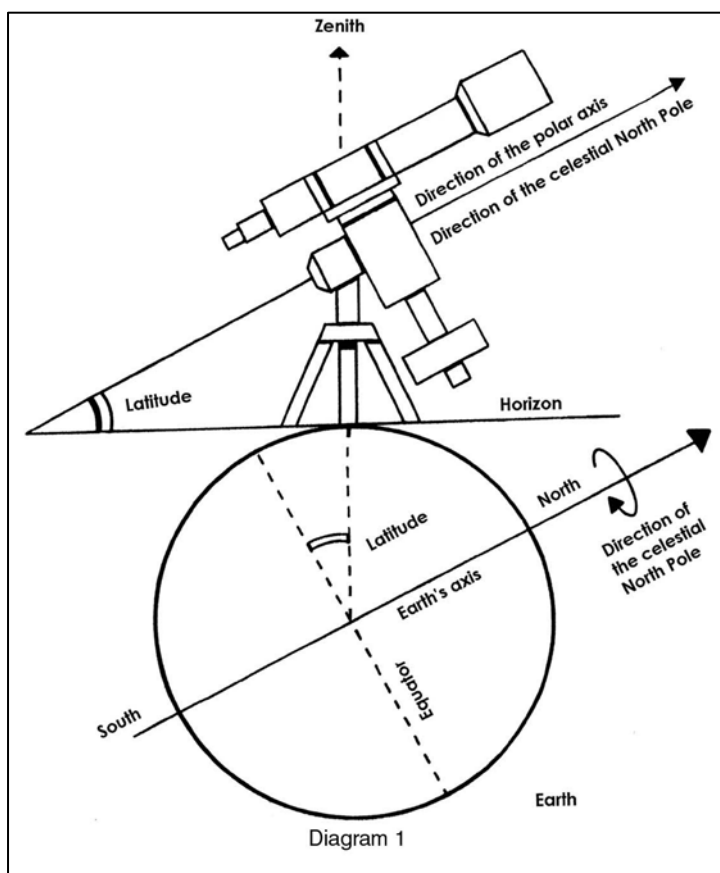

ASSEMBLY INSTRUCTIONS

Please read all instructions before attempting to set up your 1200 mount. The Model 1200 is very rugged, however like any precision instrument, it can be damaged by improper use and handling. Please refer to [Diagram 2](#) for an illustration of the mount. The parts are labeled so that we can establish common terminology.

The following terms and abbreviations are used interchangeably in these instructions:

polar axis = right ascension axis = R.A. axis = R.A. housing

declination axis = dec. axis = dec. housing

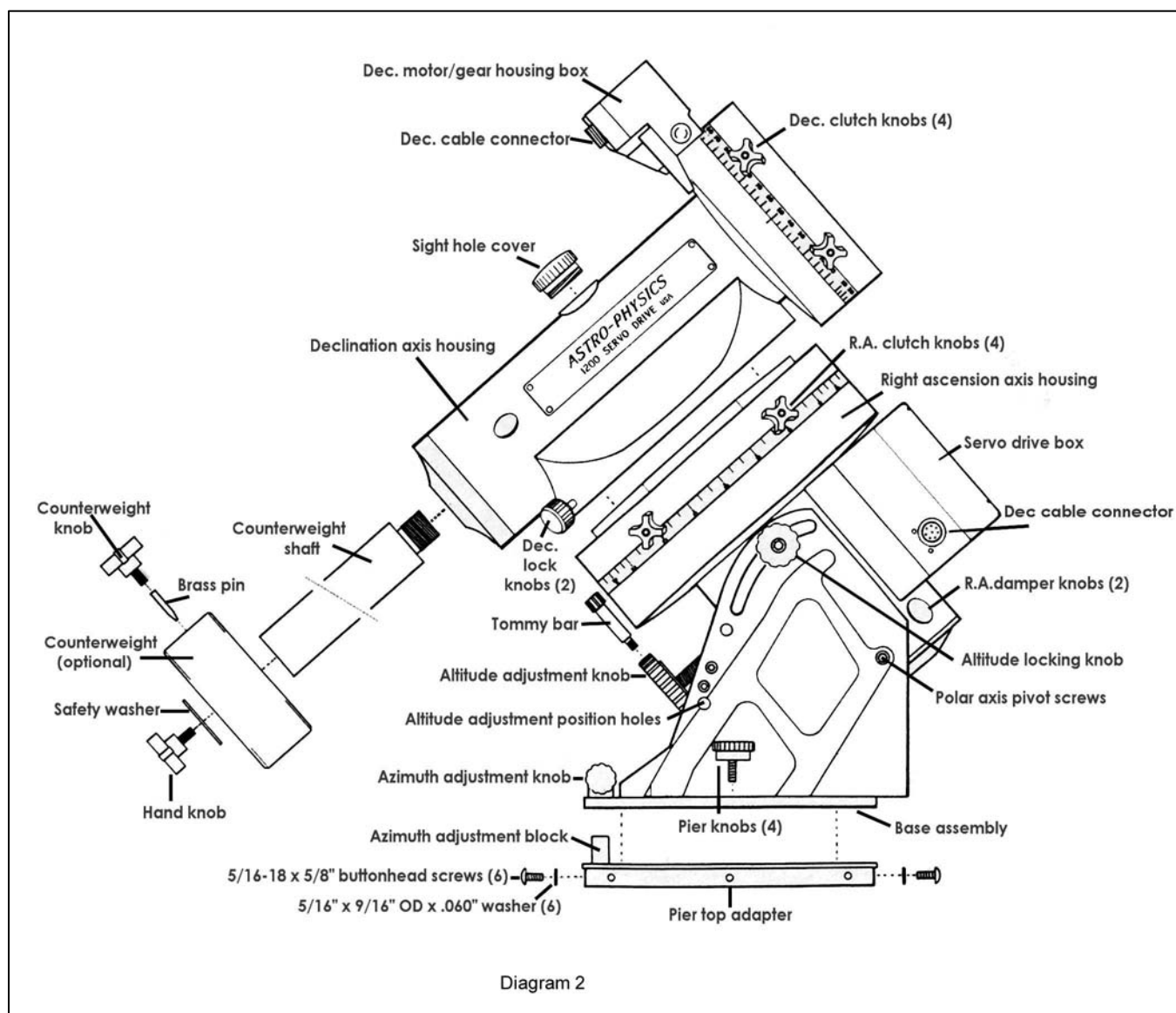

Before You Leave Home

Since most of us must set up our instruments in the dark, in the cold or while battling mosquitoes; a bit of preplanning and organization is important. There are few simple things that can be accomplished in the comfort of your home before heading outside.

Gross Latitude Adjustment

The latitude range of the 1200 mount is approximately 20-68 degrees. Since most astronomers typically observe within one latitude range, this adjustment is made just once, if at all. Prior to shipment, we preset the mount to your latitude range for your convenience. If you travel to another observing location, determine the latitude of your observing site and make the appropriate adjustment.

The four positions for the altitude adjustments have the following approximate ranges:

- 55 degrees to 68 degrees latitude - top position
- 37 degrees to 59 degrees latitude - third position
- 28 degrees to 50 degrees latitude - second position
- 20 degrees to 37 degrees latitude - bottom position

How to change the position of the altitude adjuster bar

1. Use only the R.A. axis. DO NOT attempt to make these adjustments with the declination axis in place and certainly not with an instrument fully mounted.
2. Loosen both altitude-locking knobs about 1 turn.
3. Locate the side of the polar axis that does **not** have the motor/gear housing box. Loosen (about 1 turn) the polar axis pivot screw and altitude adjuster bar fixing screws on this side only. With your hand, push the polar axis upwards so that the altitude locking knobs are positioned at the top of the altitude slot (this is the maximum altitude position) Some resistance will be felt with this operation as you are pushing against the weight of the polar housing and the resistance of the remaining polar axis pivot screw (which has not been loosened).

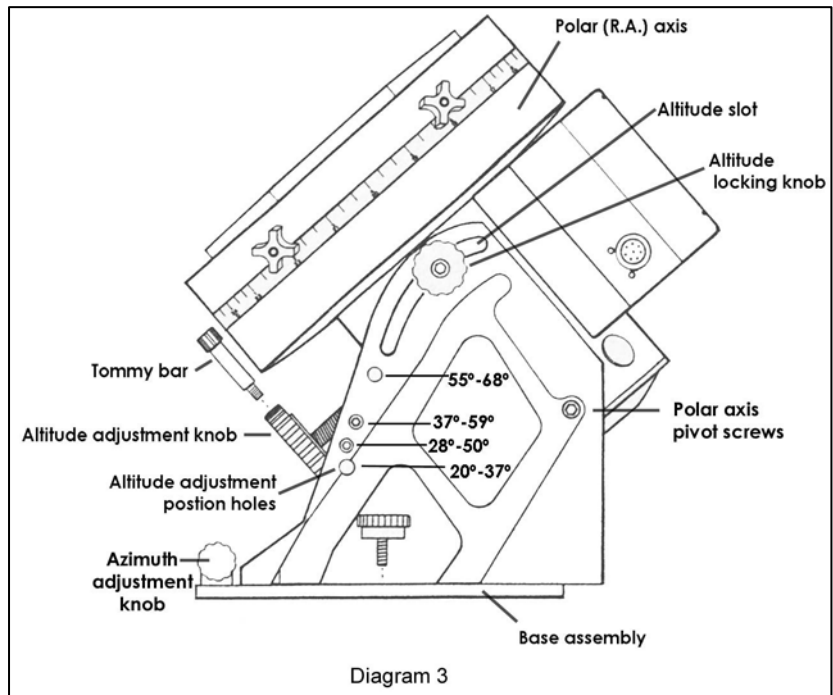

4. Before attempting to move the altitude adjuster bar, you must tighten the altitude-locking knob on the motor/gear housing side. This will prevent any downward movement of the polar axis during positioning of the altitude adjuster bar.
5. While supporting the altitude adjuster bar, remove the two screws that support it on each side (4 screws in all), but keep the two ends of the bar in contact with the side of the mount, don't remove it completely (this tip is for your convenience).
6. Determine the latitude range that you

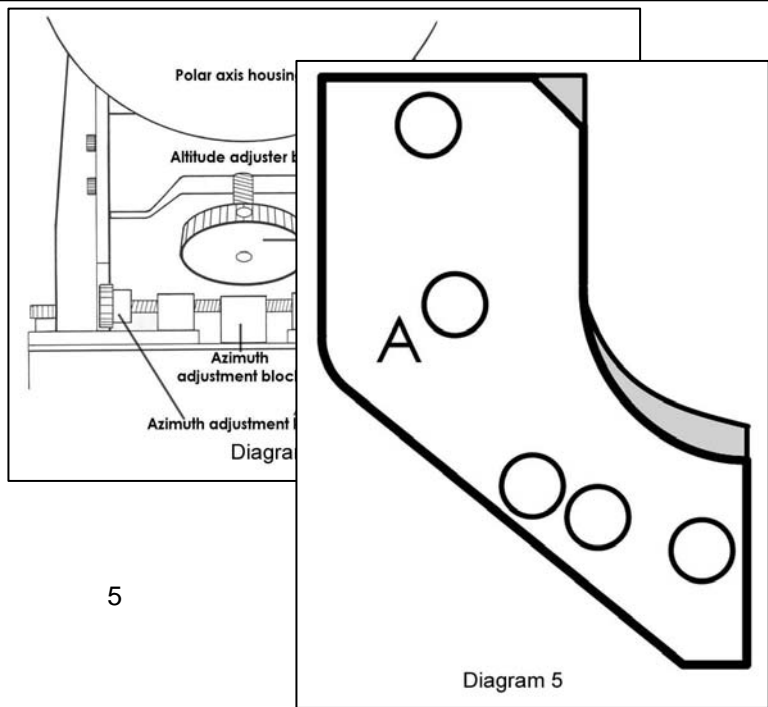

need (refer to Diagram 3) and position the hole that is marked "A" in Diagram 5 at that location. Note that this hole is located at the rounded part of the altitude bar.

7. Attach two of the screws (one on either side of the adjuster bar), but do not tighten. Rotate the altitude adjuster bar around this pivot point until one of the other holes lines up. Insert the remaining two screws. Lightly tighten so that you still have some ability to move the bar.
8. Note that the altitude adjustment knob is attached to a threaded rod that travels through the altitude adjuster bar. Turn the knob so that the altitude adjuster bar is positioned approximately in the middle of the threaded rod. You should see about half of the threaded rod protruding from both sides of the altitude adjuster bar. This will allow you to move the mount fully within the altitude range.
9. At the end of the threaded rod mentioned in the last step, you will see a small brass altitude adjuster thrust pad. This is the part that will come in contact with the polar axis as you ease it back into position. Loosen the altitude-locking knob (motor/gear side) and lower the polar axis so that it rests comfortably on this pad. The threaded rod should be positioned at a right angle to the polar axis housing. Firmly tighten the altitude adjustment screws.
10. Turn the altitude adjustment knob to raise or lower the polar axis to your approximate observing latitude. Tighten the altitude locking knobs with finger pressure only. You do not need to tighten with the hex key.
11. Firmly tighten both polar axis pivot screws with the hex key.

Attach Pier Adapter to Pier Post

If you purchased the pier from Astro-Physics, the pier top adapter of the 1200 may be already attached to the top of the pier. If you are constructing your own pier or tripod, you will need to incorporate this part. The pier adapter was designed to fit into a 10" x 0.094" wall tube. Use six (6) screws to attach this part. Note that with the Astro-Physics pier, you can orient the pier adapter so that one of the pier legs faces "north" or "south" as you prefer.

Assemble Pier (purchased separately)

Begin by assembling the portable pier at the desired observing location. Note which direction is north.

1. Slide the three legs onto the nubs of the base and rotate the assembly so that one of the legs points toward north (or south, if that is your preference).
2. Place the pier tube on the base orienting the center azimuth block directly over the leg that is oriented to the north.
3. Attach the tension rods. The turnbuckles should be drawn tight until the whole assembly is stiff enough to support your weight without movement.

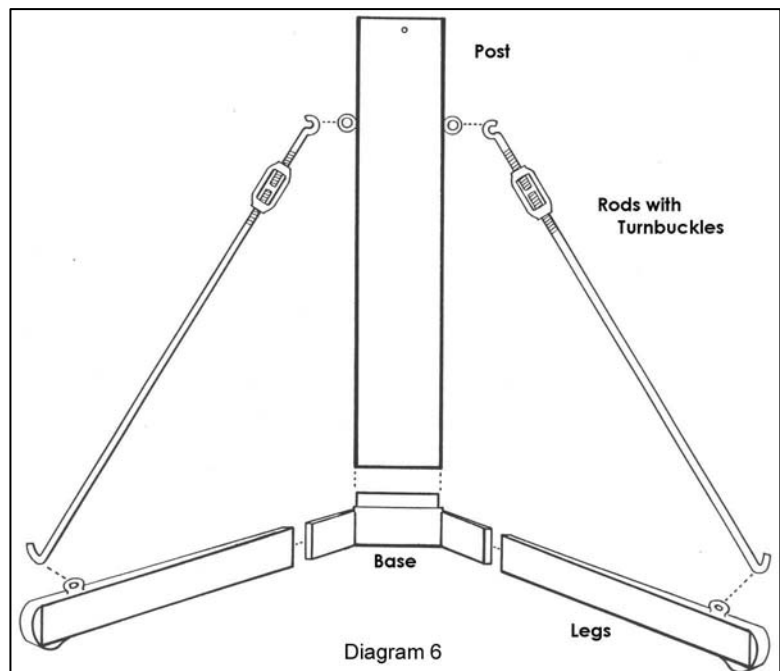

Assemble Polar Axis Assembly to Pier or Tripod

In order to track the motion of astronomical objects, the polar axis must be positioned so that an imaginary line drawn through the center of the axis points toward the celestial pole. At this stage of the assembly process, you want to position the mount so that it points roughly north.

1. Remove the four (4) hand knobs on the pier top adapter and keep them close at hand.
2. Prior to lifting the polar axis assembly into place, turn the fine azimuth adjustment knobs so that the space between them is wide enough to allow the center azimuth block to fit easily between them. Ensure both pier top and polar axis assembly mating surfaces are clean and free of dirt.

- Place the polar axis assembly onto the pier top adapter so that the center azimuth block fits between the fine azimuth adjustment knobs.
- Move the base of the polar axis assembly so that the threaded holes of the pier top can be seen through each of the four slots.
- Thread the four hand knobs loosely in place (you will tighten these later after polar alignment).

Altitude and Azimuth Adjustments - Rough polar alignment

For rough polar alignment, your goal is to sight the celestial pole when looking through the polar alignment sight hole in the center of the polar axis. You will need to make altitude (up/down) and azimuth (side to side) adjustments to the position of the mount.

We recommend that you do your rough polar alignment with the R.A. axis only since you will be making major adjustments to the position of the mount at this time. The remainder of the mount, telescope and counterweights would add considerable weight and require more hand effort. Later, you will do your final polar alignment with the telescope and counterweights attached, but the adjustments will be small.

- If the R.A. encoder housing and encoder adapter are installed (part # ENC1200 - Mounted Encoders to use with Digital Setting Circles - are available as an optional purchase), you may remove them to complete these steps. Please refer to the section entitled "[INSTALLATION OF ENCODERS AND ENCODER HOUSINGS - 1200 MOUNT](#)" on page 13. Alternatively, you can simply sight up the side of the polar axis to see Polaris.
- If you examine the polar axis assembly, you will see that the center of the R.A. shaft is hollow. If you have not done so already, loosen (1/2 turn) the four pier knobs.

NOTE: If you have already attached the Dec. axis, remove the sight hole cover and rotate the internal Dec. shaft by moving the top of the Dec. axis (or the cradle plate if it is attached) to reveal the sight hole that has been drilled into it. Now, you can look through the shaft to the other side.

- Azimuth adjustments:** Move the entire pier or tripod east or west until the mount is oriented approximately towards the pole (an imaginary line drawn through the hollow shaft). Use the two fine azimuth adjustment knobs, one on each side of the mount, to make adjustments. You must back off the opposing azimuth knob in order to move the other knob in that direction. Please refer to [Diagram 4](#).
- Altitude (latitude) adjustments:** Loosen the altitude locking knobs. Move the polar axis up or down with the large altitude adjustment knob located in the front of the polar axis assembly. The tommy bar can be positioned in any of the threaded holes located in the altitude adjustment knob. Use this bar to help you turn the knob. Please refer to [Diagrams 3 and 4](#). We have found that using the turnbuckle on the north leg of our pier also can make fine altitude adjustments, if used.
- Continue your azimuth and altitude adjustments until you can sight Polaris in the polar alignment sight hole. At this point, you have achieved rough polar alignment, which may be sufficient for casual visual observations, if you are not planning to slew to target objects with the keypad. When the R.A. motor is engaged, it will compensate for the rotation of the earth and keep the target object within the eyepiece field of view. Your target object will slowly drift since polar alignment at this stage is only approximate. However, you can make corrections with your hand controller, as we will discuss later.
- Tighten the altitude locking knobs by hand.
- Tighten the pier knobs firmly by hand.

Assemble Declination Axis

- Do not have your telescope or counterweights connected to the Dec. axis assembly for either assembly or disassembly of the Dec. and RA axes.
- Position the R.A. axis as shown in [Diagram 7](#) with the pocket "A" at the top, opposite the altitude adjuster knob. Firmly tighten R.A. clutch knobs.
- During shipment, the Dec. axis assembly lock knobs will be fully screwed into the Dec. axis. For correct assembly, these lock knobs should be unscrewed at least 7 full turns and no more than 8.5 full turns. This is between 5/16" and 3/8" out from the "shipped"

7

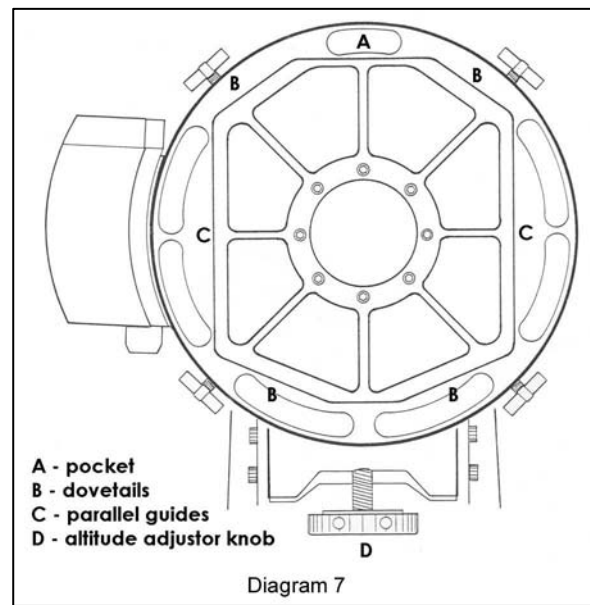

tightened position.

Note: These lock knobs can be completely removed from the Dec. axis assembly with about 9.5 full turns out.

4. Position the Dec. axis above the R.A. axis as shown in **Diagram 8**, a light movement (wiggle) in the downward direction (arrow "A") will help to correctly seat the principle dovetail(s) and parallel guides.
5. When both Dec. and R.A. assemblies are fully seated, hand tighten both Dec. lock knobs.
6. Thread the counterweight shaft into the Dec. axis.
7. Remove the hand knob and safety washer from the base of the counterweight shaft. Add sufficient counterweights (10 or 18 lb. counterweights are purchased separately) to the declination shaft to balance the telescope you intend to use. Always use two hands to attach or move them on the shaft.
8. Reattach the hand knob and safety washer to the end of the declination shaft. This will help to prevent injury if someone accidentally loosens the counterweight knob.

NOTE: Firm tightening of the counterweight knob will not damage the surface of the counterweight shaft. The pin that tightens against the stainless counterweight shaft is constructed of brass. Likewise the bronze sleeve that has been press fit into the center of the counterweight will prevent marring of the shaft as you move the counterweight up and down.

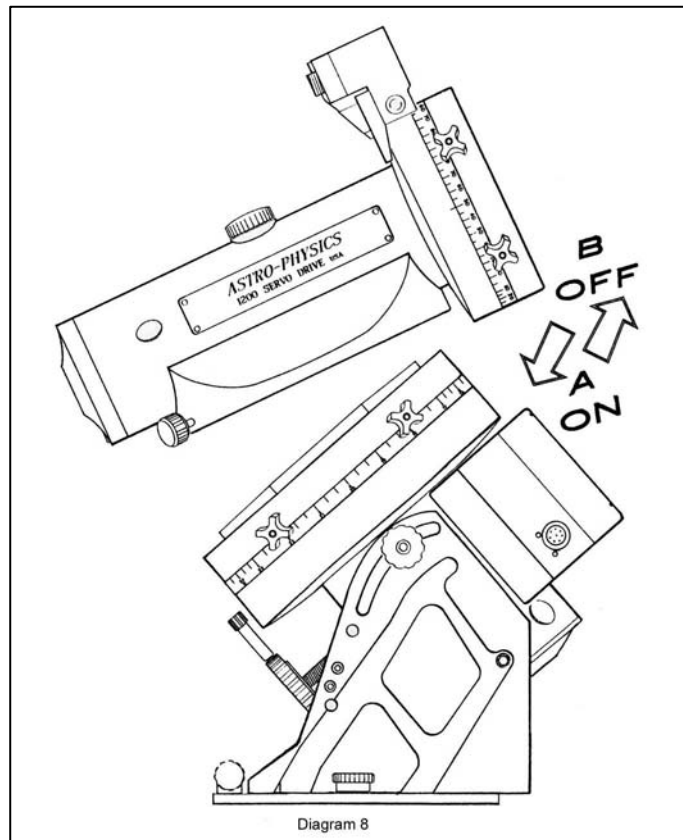

Removing Declination Axis at the End of your Observing Session

1. Unscrew the lock knobs 5.5 to 7 full turns (this is still 5/16" to 3/8" out from the fully tightened position) and slide/tilt the Dec. axis assembly in an upwards direction (arrow "B").
2. For transport/storage we recommend fully tightening the lock knobs.

Attach Mounting Plate (purchased separately)

Several mounting plates are available for the 1200 mount. If you own more than one instrument, you may need more than one plate. Follow the appropriate directions for the plate(s) that you have.

18" FLAT MOUNTING PLATE (FP1800)

This plate is 18" long and 7.5" at its widest point in the center. The width of the plate tapers to 5.5" at each end. Four pairs of keyhole slots that measure 3.2" between centers are provided. The two inner pairs are 13.75" apart and the outer two pairs are 17" apart. You can drill additional holes to suit your needs. This plate also fits the 900 German Equatorial.

Attach this plate with six 1/4-20 x 1" flat head socket cap screws at the locations indicated by the filled holes on the diagram.

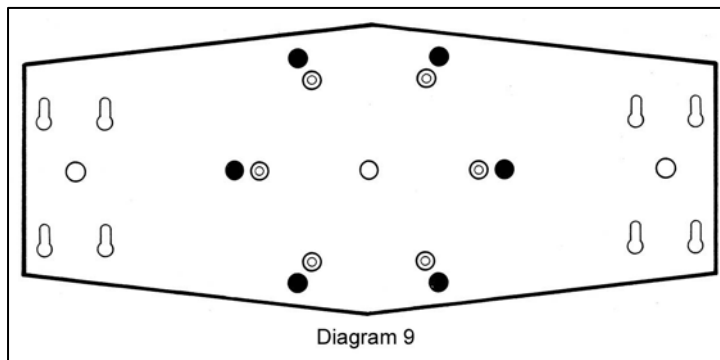

Diagram 9

15" RIBBED MOUNTING PLATE (1200RP15)

This plate is 14.75" long, 7.75" at its widest point 5" at each end and 1" thick. The underside of the plate is carved into a ribbed pattern to maximize the strength and minimize the weight - 3 lbs. A pair of keyhole slots that measure 3.2" between centers are provided at each end. The distance between the pairs is 13.75".

Attach this plate with six 1/4-20 x 3/4" socket head cap screws at the locations indicated by the filled holes on the diagram. **Note that the plate is asymmetrical. Attach the plate so that the long end points toward the sky.**

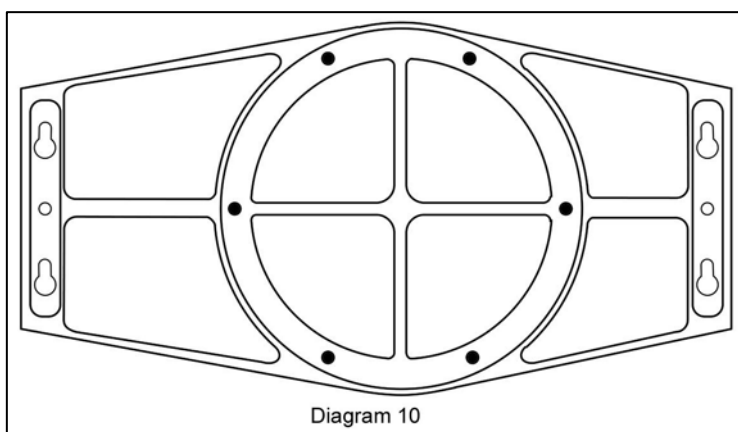

Diagram 10

24" RIBBED MOUNTING PLATE (1200RP)

For larger instruments, the ribbed structure of this plate provides the maximum support. Our machinist begins with thick aluminum plate and carves a strong rib structure. The final result is 1.5" thick, 24" long and 7.6" at its widest point. The width of the plate tapers to 5.5" at each end. A pair of keyhole slots that measure 3.2" between centers are provided at each end. The distance between these pairs of holes is 23". Due to the ribbed structure, you may not be able to drill additional holes for non-Astro-Physics mounting rings. The plate weighs an amazing 9.5 lbs. for its size. This is a view of the rib structure on the underside of the 24" plate.

Attach this plate with six 1/4-20 x 1" socket head cap screws at the location indicated by the filled holes on the diagram.

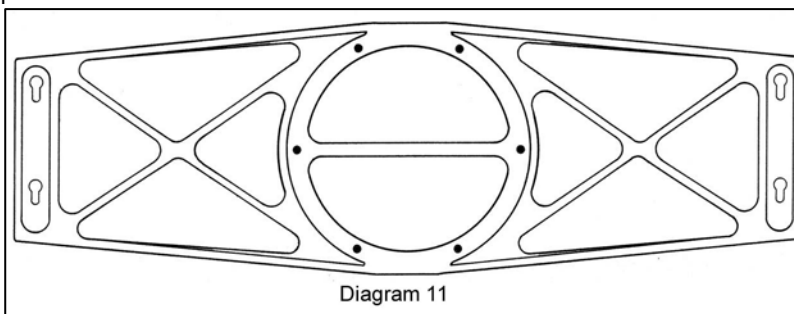

Diagram 11

DOVETAIL FOR LOSMANDY D SERIES PLATE (DOVELM)

This Astro-Physics plate attaches to the 1200, 600E, 900 and 1200 mounts. If you already own one of the Losmandy DAP series (fits Astro-Physics refractors), DC series (for Celestron 8", 11" or 14" SCTs) or DM series (for Meade 8", 10" and 12" SCTs) plates, this is the mounting plate for you.

Attach this plate with four 1/4-20 x 3/4" socket head cap screws and two 1/4-20x5/8" flat head socket cap screws at the location indicated by the filled holes on the diagram.

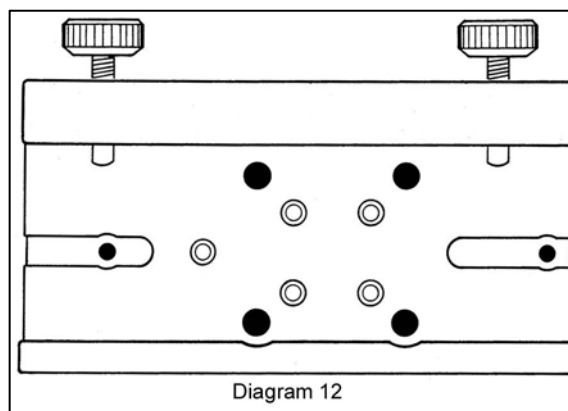

Diagram 12

Attach Mounting Rings (purchased separately)

Our flat and ribbed plates are constructed with keyhole slots at the location where your mounting rings attach. This feature enables you to partially loosen the screws on your rings just enough to insert them into the larger part of the keyhole, then slide the rings to the narrow part and tighten them with a hex key. You can even accomplish this with the rings on the scope, although this maneuver may be difficult to accomplish with a large, heavy instrument.

We prefer this keyhole method to the standard way of completely removing the screws and dropping them in the grass.

Fine Polar Alignment

For casual observation with the 1200SMD you may skip this section and move to “**OPERATION OF THE MOUNTING**” on page 11 (tighten your altitude locking knobs (2) and pier knobs first). If you plan to use any of the go-to functions of the 1200GTO or do astrophotography, you must polar align.

1200SMD Model - Methods for fine polar alignment

- Polar axis telescope - The north celestial pole can be viewed through the polar axis with the optional polar axis telescope. Please read the section “**POLAR ALIGNMENT TELESCOPE AND ILLUMINATOR**” on page 15.”
- JMI Digital Setting Circles - Please read the instructions included with your JMI unit. You must have the encoders installed on your 1200 mount (part # 1200ENC). Refer to the section “**INSTALLATION OF ENCODERS AND ENCODER HOUSINGS -1200 MOUNT**” on page 13.
- Star Drift method - Traditionally, this has been regarded as the most accurate method of polar alignment, however it is also the most time consuming. If you are planning long exposure astrophotos, we suggest that you use either the polar axis telescope or JMI digital setting circles, then tweak the final polar alignment by star drifting. Please refer to the recommended reading list at the end of this manual.

1200GTO Model - Methods for fine polar alignment

- GTO Keypad - Please refer to the instruction manual for the GTO Servo Drive and read the section describing the “Startup Sequence”.
- Polar axis telescope, JMI Digital Setting Circles, Star Drift methods - Please refer to the previous section regarding the 1200SMD model. All of these methods can be used for the GTO as well. However, if you use the GTO keypad, you will follow the startup routine to confirm or further tweak your alignment.

Altitude and Azimuth Adjustments

1. Loosen the altitude locking knobs (2) and pier knobs (4) and refer back to the section on “**Altitude and Azimuth Adjustments - Rough polar alignment**” on page 7.
2. Follow one of the methods of polar alignment mentioned above.
3. When polar alignment has been achieved, tighten at these locations (note that the polar axis pivot screws should have been tight throughout the fine polar alignment process):

Altitude locking knob (2) - hand tighten
Pier knobs (4) -hand tighten
4. For a permanent installation, all knobs in step 3 above may be firmly tightened with the assistance of a hex wrench.

OPERATION OF THE MOUNTING

R.A. and Dec. Damper Knobs

The R.A. and Dec. damper knobs are not intended as axis locks. They should be tightened with light finger pressure so that a slight resistance can be felt when pushing an unclutched axis by hand. This really adds to the "feel" at the end of the scope with the drives adjusted correctly.

R.A. and Dec. Clutch Knobs

1. What do they do?
The four R.A. and four Dec. clutch knobs depicted in **Diagram 2** have the function of connecting the R.A. and Dec. axes to their respective drive worm wheel gears. Their function is progressive, from no tension (axes free to move - as required during correct balancing of the telescope) to a completely "locked up" state.
2. How can you find out what they really do?
As shipped, all 1200 mounts have all **four** R.A. and Dec. clutch knobs firmly hand tightened. This will give you a good idea of the maximum tightness (clutch action) that can be achieved by hand effort alone. At this point, you must bear in mind that for optimum performance all **four** clutch knobs on each axis (R.A. or Dec.) should be tightened evenly with the same tension i.e. all four half tight, all four fully tight, etc.

In order to feel the effect of the clutch knobs, you may wish to partially assemble your mount. Fit together the R.A. and Dec. assemblies plus mounting plate and counterweight shaft. Do not put scope and counterweights on at this stage. With the above assembly (with the clutch knobs firmly hand tightened - "as shipped"), you can feel the amount of force needed to move each axis by hand. Grab each end of the telescope mounting plate and move it with a backward and forward movement of the Dec. axis. You will feel considerable resistance to this motion. Perform the same operation on the R.A. axis by moving the counterweight shaft backward and forward. With a well balanced telescope, the above tightness of the clutch knobs will be sufficient for all normal conditions of use.

Now if you proceed to mount up and balance your telescope you can "feel" what this resistance in R.A. and Dec. (movement backwards and forwards) is like when you make these motions from the eyepiece end of your telescope as you would during normal use when slewing (pushing) by hand to acquire an astronomical object within the field of view of your finder or scope.

3. How tight can the clutch be and can you do any damage by pushing against them?
The maximum tightness of this clutch system is 1/3 turn (with a 5/32 allen key) further in than the tension you can achieve with the knobs by hand. You will see that each clutch knob has a 5/32 hex socket for tightening with an allen key. With this extra 1/3 turn on each clutch knob, the axis (axes) will be considered completely "locked up" and you should not attempt to push your scope by hand against this "locked up" resistance, or undue stress will be placed on the worm wheel/worm and bearings.

However, if you are undertaking a very long astrophoto exposure, it is advisable to increase the pressure on each clutch knob (with the 5/32 key) by about 1/8 turn on Dec. and 1/8th turn on R.A. You may safely slew the scope by hand with this tension, however you will notice considerably more effort is required to achieve movement. This is the absolute maximum tension that can be used for hand slewing. As a general rule, if you have a big scope (7" or 8" refractor) with all the accessories, you will need more clutch tension than a 5" or 6" scope.

Balancing Your Telescope

For proper operation, the telescope must be adequately counterbalanced. Start by balancing the tube assembly.

1. Tighten the 4 R.A. axis clutch knobs.
2. Loosen the 4 Dec. axis clutch knobs (about 3/4 to 1 turn) so that the telescope moves freely about the declination axis (be careful because if your telescope is significantly out of balance, it may swing rapidly in the out of balance direction!)
3. Position the R.A. axis so that the counterweights are in their "lowest" position i.e. the declination axis assembly is in the meridian (this is the usual way that German equatorials are depicted, as shown in diagram 2.)
4. Loosen the tube mounting rings and slide the tube up and down for balancing. This is best done with the tube in the horizontal position.

5. The scope is balanced when it stays put (does not move) with the clutches loose and movement back and forth about the declination axis has the same feel in both directions.
6. Now, tighten the declination axis clutch knobs and position the telescope horizontal and the declination axis horizontal. The center of the counterweights is now the same height as the middle of the tube.
7. Loosen the R.A. clutch knobs (again be careful, because if your scope is significantly out of balance it may swing rapidly in the out of balance direction).
8. Move the counterweight(s) up or down to achieve the correct balance in R.A. Again, movement back and forth about the R.A. axis should have the same feel in both directions.
9. Try to anticipate any balance problems due to the extra weight of diagonals, heavy eyepieces, finders, solar filters, etc. If the scope moves by itself, when the clutches are loose, then the scope is not counterbalanced adequately. A small amount of imbalance is permissible and indeed desirable.

SERVO MOTOR DRIVE

Refer to the relevant instruction manual for use of your servo drive system:

GTO Control Box for Servo Drive

SMD Control Box for Servo Drive

MOUNT MAINTENANCE AND ALIGNMENT

Under normal operating conditions, minimal maintenance is required. Every 12 months the clutch knobs (4 for Dec. and 4 for R.A.) should be removed and 1 or 2 drops of light oil (3 in 1 household oil) should be put in the exposed hole. If the R.A. and Dec. axes are attached together for a long time in outside conditions (i.e. in a permanent observatory) then the mating surfaces should be lightly oiled or greased - if you expect to get them apart again after 10 years.

Your 1200 is a precision instrument with very accurate worm and wheel adjustments. Please be careful if you place the mount on a flat surface, i.e. the ground or trunk of your car. The gear alignment may be affected if the R.A. and Dec. motor/gear box assemblies sustain undue lateral force. This is true of any fine instrument. We suggest that you transport and store the mount in a case or in a well padded box.

NOTE: If your battery runs low, the declination motors will stop first, though the R.A. will continue to drive until the power is drained.

If any problems occur, please don't hesitate to contact Astro-Physics for assistance.

ASTRO-PHYSICS INC.
11250 Forest Hills Road
Rockford, IL 61115
Telephone: (815) 282-1513
Fax: (815) 282-9847

Recommended reading from our staff:

[The Backyard Astronomer's Guide](#), Terence Dickinson and Alan Dyer, Camden House Publishing, 1991

The authors, both former editors of *Astronomy* magazine, offer practical insight into astronomical equipment, finding your way around the sky, polar alignment, using setting circles, and astrophotography. This book provides excellent explanations and is well organized and illustrated.

[All About Telescopes](#), Sam Brown, Edmund Scientific Company, 1975. Excellent information regarding the principles of mount construction and operation, using setting circles, eyepiece projection, etc. Illustrations and formulas galore. Many of the instruments pictured are outdated, however the underlying principles are timeless.

[Norton's 2000.0 Star Atlas and Reference Handbook](#), edited by Ian Ridpath, J. Wiley Publishers, 1989. Star maps, information regarding polar alignment of German equatorials and observing techniques.

INSTALLATION OF ENCODERS AND ENCODER HOUSINGS -1200 MOUNT

1200ENC (purchased separately)

Parts List:

- 1 Right Ascension (R.A.) Encoder housing (black anodized)
- 1 Declination (Dec.) Encoder housing (black anodized)
- 1 R.A. Axis Adapter (clear anodized - silver colored), labeled R.A.
- 1 Dec. Axis Adapter (clear anodized - silver colored), labeled Dec.

To install your encoders, first remove the telescope from your mount. Remove your declination counter weight(s) and declination counterweight shaft.

Fitting Declination Encoder Housing

If the encoders were purchased with the 1200 mount, it is likely that the declination axis adapter and encoder housing have already been installed. No further action will be required as this encoder will remain in place.

1. If the encoders were purchased separately, the silver-colored Dec. axis adapter may be inside the black Dec. axis encoder housing. If it is, remove it now.
2. Locate the counterweight shaft adapter (the black anodized part that the counterweight threads into) on the Dec. axis. When we assembled the mounts, we threaded this on rather tightly, so you will need some extra leverage to remove it. Locate the hole that was drilled into the part and find some object that you can insert. We suggest that you use one of your allen head wrenches that is wrapped in masking tape so that you do not mar the finish of the part. You may need to apply a good deal of force so it may be easiest to do if the mount is on the pier so that it won't move.
3. Thread the Dec. axis adapter into the end of your Dec. axis. Final tightening should be done with firm hand pressure. Normally the Dec. axis adapter will not be removed.
4. If you look into the black encoder housing, you will see the encoder itself mounted at the rear of the housing. When this installation procedure is complete, the encoder shaft will insert into the center hole of the Dec. axis adapter. This allows the encoder to read the motion of the declination shaft as the declination axis moves.
5. Thread the Dec. encoder housing onto the Dec. axis housing of the 1200 mount. You may need to wiggle the encoder housing gently to engage the shaft of the encoder with the hole in the center of the Dec. axis adapter. When the threading is complete, tighten up with firm hand pressure (or insert your special "tool" from above and tighten firmly) since normally this encoder housing will not be removed.
6. The counterweight shaft may now be rethreaded into the rear of the Dec. encoder housing.

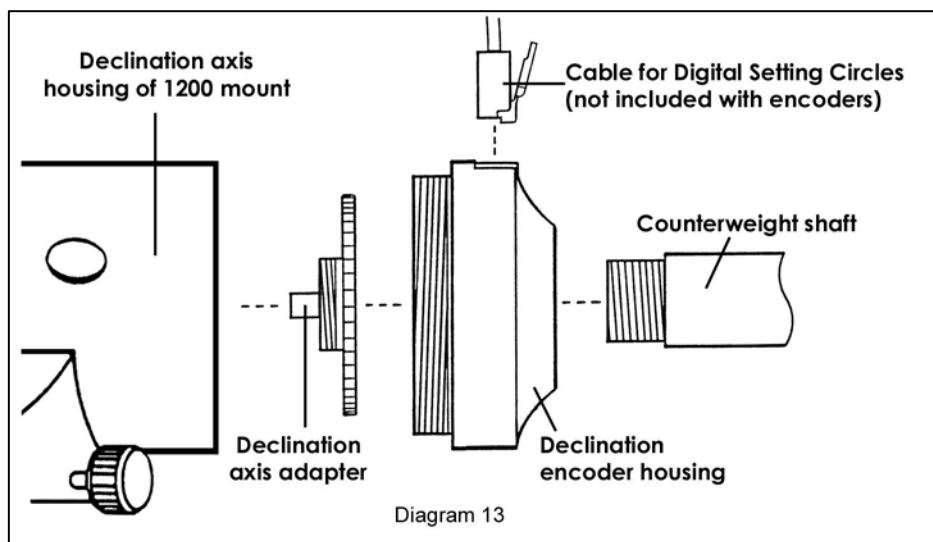

Fitting Right Ascension Encoder Housing

If the encoders were purchased with the 1200 mount, it is likely that the right ascension axis adapter and encoder housing have already been installed. Please continue to read these directions since you may need to remove and reinstall the encoders if you use a polar alignment scope. Since the polar axis telescope and R.A. axis adapter thread into the same location, you will need to switch back and forth between them as needed. If you use the JMI NGC MAX or Mini MAX Digital Setting Circles, you can use the "polar align" mode in these units instead of a polar alignment scope!

1. If the encoders were purchased separately, the silver-colored R.A. axis adapter may be inside the R.A. axis encoder housing. If it is, remove it now.
2. Thread the R.A. axis adapter into the end of your R.A. axis (if your polar alignment scope is fitted you must remove this first along with the polar alignment scope adapter). Use moderate hand pressure to tighten the R.A. adapter since you may need to remove it to install the polar axis telescope at a later time.
3. If you look into the black encoder housing, you will see the encoder itself mounted at the rear of the housing. When this installation procedure is complete, the encoder shaft will insert into the center hole of the R.A. axis adapter. This allows the encoder to read the motion of the R.A. shaft as the right ascension axis moves.
4. Now thread the R.A. encoder housing onto the R.A. axis housing. You may need to wiggle the encoder housing gently to engage the shaft of the encoder (located within the R.A. axis housing) with the hole in the center of the R.A. axis adapter. Again, use moderate hand pressure as you may wish to remove this at some time.
5. The hardware for your encoders is now installed. For actual set-up procedures for Micro MAX, Mini MAX or NGC MAX, digital readouts refer to the relevant operating manual from the manufacturer. We provide some startup tips in our instruction sheet entitled "Using JMI Setting Circles".

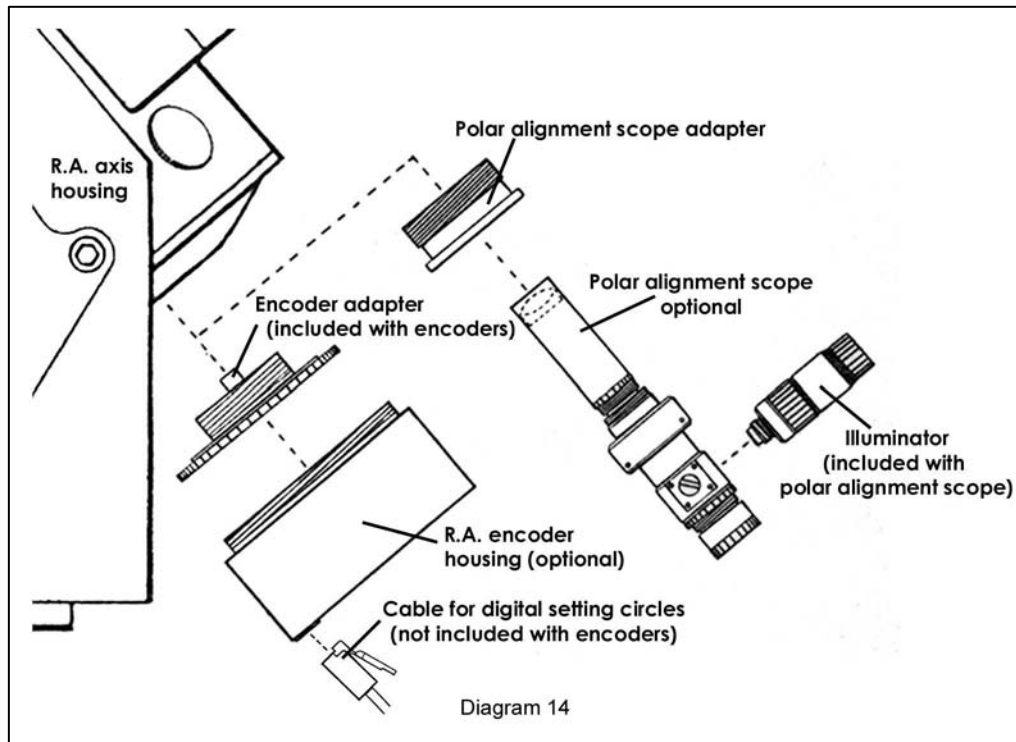

Periodic Maintenance

If you remove the R.A. encoder frequently, you may wish to use a very tiny amount of auto grease on the mating threads.

POLAR ALIGNMENT TELESCOPE AND ILLUMINATOR

The polar alignment telescope (also called polar axis scope) will help you to align your mount with the precise north celestial pole. If your mount is aligned properly, your drive motor will track celestial objects accurately throughout the night. This will allow you to sit back and enjoy the view without constantly adjusting your telescope to follow stars that are drifting continually out of your eyepiece. If you plan to take astrophotos, proper alignment is critical so that the images recorded on film are as tight and round as possible. Improper alignment will result in elongated star images. The polar alignment scope is for use in the Northern Hemisphere only.

This scope utilizes a special-condenser system, which makes it possible to view the entire reticle in a single glance. The reticle has a special setting pattern that makes alignment easy. The dark field illuminator is a red LED which illuminates the reticle so it can be seen clearly against the night sky.

Polar Alignment Scope

- Specifications:
- Magnification: 5X
 - Achromatic objective lens: 20mm
 - Eyepiece: K22mm (Diopter adjustable)
 - Field of view: 8 degrees
 - Reticle: Condenser system setting pattern
 - Accessory: Allen wrench (for M3 1.5mm, included)

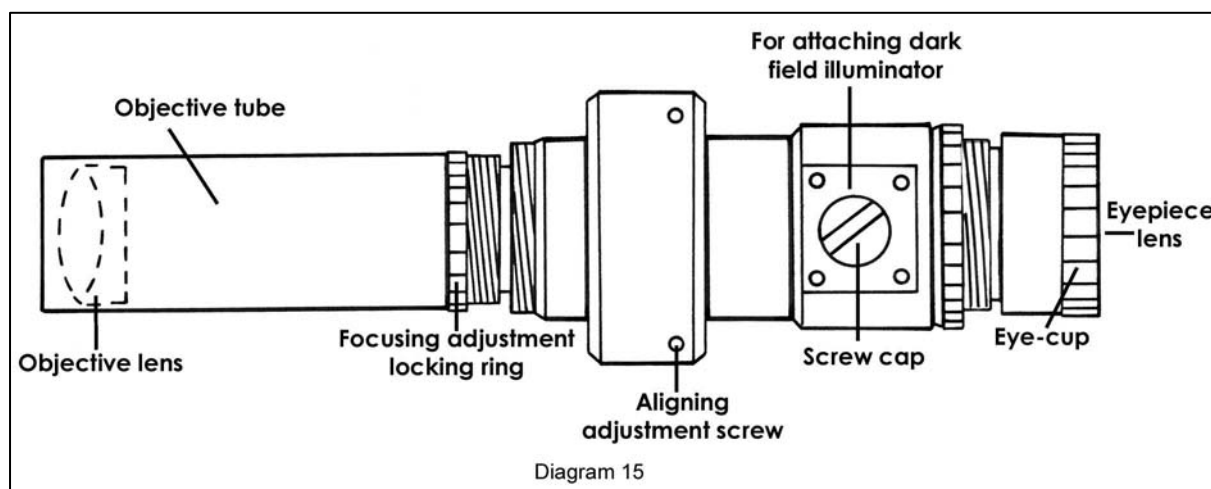

Illuminator

- Specifications:
- Rated voltage: 3VDC
 - Power consumption : 16mA
 - Light: red LED
 - Battery: Button-type: two Varta V76 PX or equivalent
Your camera dealer can help you.
Radio Shack hearing aid battery, P675M
cat. no. 23-145, pkg. of 6 for \$2.79

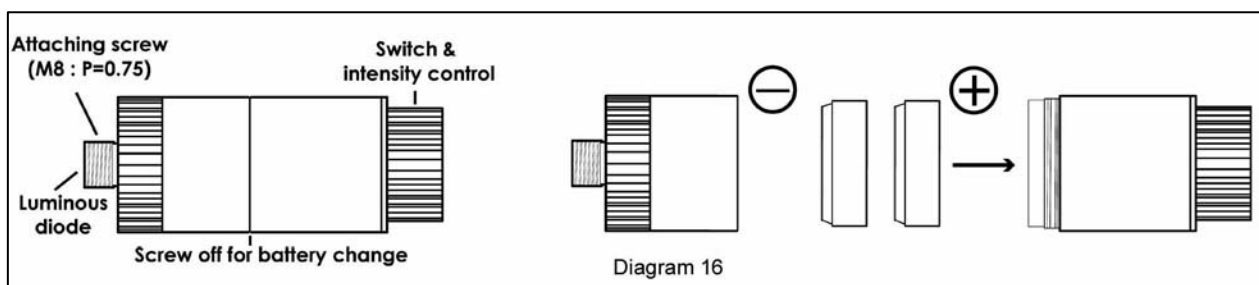

Installation and Adjustments

We recommend that you install and adjust your polar alignment telescope in daylight, without the telescope and counterweights, following the instructions in this section. Once the reticle is properly adjusted so its center circle is mechanically and optically aligned with your mount, the alignment will remain stable, barring any strong shock to your mount.

1. Adjust the diopter: Loosen the diopter adjustment locking ring and turn eyepiece until the reticle is sharply in focus. Tighten the locking ring to lock the eyepiece in place.
2. Adjust the focus: Loosen the focusing adjustment locking ring and turn the objective tube until you get a sharply focused image of a distant object. Tighten this locking ring to lock the objective tube in place.
3. Remove the sight hole cover on the declination axis and rear cap (or encoder adapter and housing) on the polar axis.
4. Turn the declination axis until the hole in the shaft is aligned with the sight hole. You will be able to see through the mount along the line of vision represented by the solid line in the diagram.
5. Thread your polar alignment telescope into the rear of the polar axis.
6. Using the mount's azimuth and altitude adjustment knobs, aim your polar axis telescope at a distant object, such as the top of a telephone pole, placing it within the center circle of the reticle. Please refer to the section entitled "Altitude and Azimuth Adjustments - Rough polar alignment" on page 7 for specific details. Tighten the altitude locking knob to hold the mount in position.
7. Turn the right ascension axis while looking through the polar axis telescope. You will see the distant object moving around and out of the central circle.
8. Using the Allen wrench provided, adjust the polar alignment scope's aligning adjustment screws until the distant object is again within the center circle of the reticle. You are adjusting the polar alignment scope to be orthogonal with your mount.
9. Continue repeating these steps until the distant object does not move out of the central circle when the right ascension axis is turned. Your polar axis telescope is now aligned with your mount's polar axis.

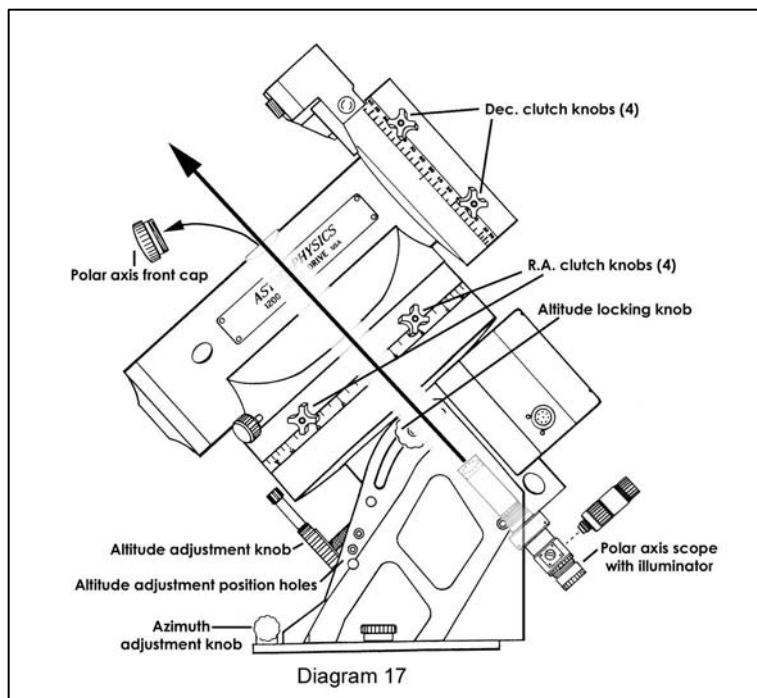

Using your Polar Alignment Telescope

1. Set up your mount according to the instructions in this manual including your rough polar alignment (refer to "Altitude and Azimuth Adjustments - Rough polar alignment" on page 7).
2. Attach the illuminator to the polar axis telescope by removing the screw and threading in the illuminator. Please note that the illuminator requires batteries (see specifications). Use the "On/Off" switch to adjust brightness.
3. Turn the declination axis until the hole in the axis is aligned with the polar axis holes. You will be able to see through the polar axis telescope along the line of vision represented by the solid line in the diagram.

4. While looking through the polar axis telescope, make adjustments to the altitude and the azimuth adjustment knobs until Polaris and Delta Ursa Minoris (the last and second-last stars in the Little Dipper's handle, respectively) are within your field of vision.

α – Polaris (Alpha Ursa Minoris)

δ – Delta Ursa Minoris

β – broken line indicates
direction toward star
outside field, it is not
important

5. Using the altitude and azimuth adjustment knobs, continue to make adjustments until Polaris is seen through the small circle closest to the center of the reticle and Delta Ursa Minoris is located within the small circle closest to the outer edge of your field of vision.
6. When proper alignment has been achieved, snug the two altitude adjustment knobs lightly to secure the polar axis and recheck alignment. If no movement has occurred, finish hand tightening the two altitude adjustment knobs and pier knobs to prevent movement when the telescope and counterweights are attached. For permanent installation, all knobs may be firmly tightened with the assistance of a hex wrench.
7. Now your mount is aligned with the pole. Remove the polar axis scope since you do not need it any longer. Remember to turn off the batteries in the illuminator. You are ready to attach your counterweights, then your telescope and begin a night of observing. Enjoy yourself!

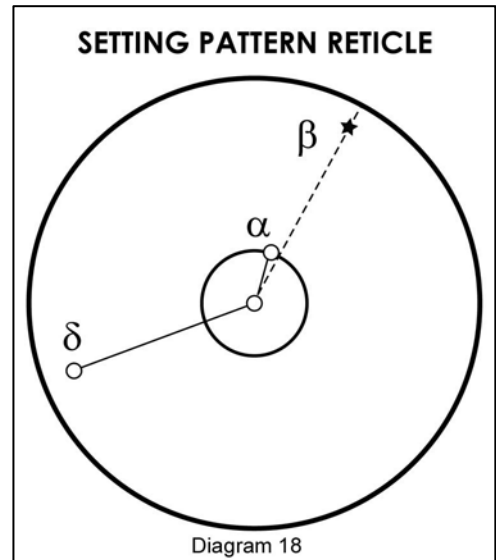

Remarks

1. Remove the batteries from the illuminator when not in use; the unit may be damaged if the batteries should leak.
2. Extremely cold temperatures may affect the brightness of the LED.