

ASTRO-PHYSICS MODEL 1200 GERMAN EQUATORIAL WITH DUAL AXIS QUARTZ DRIVE (1200DA)

MODEL 1200 PARTS LIST

- 1 Polar axis assembly (right ascension – R.A.) with stepper drive
- 1 Declination (Dec.) axis assembly with stepper drive
- 1 Pier top adapter with three 5/16-18 x 5/8" button head screws with washers
(these will be attached to your pier post if you ordered one)
- 1 Stainless counterweight shaft with washer stop and black plastic knob (knob has 5/16 thread)
- 1 Dual axis quartz frequency control box
- 1 "Y" connector cable
- 1 D.C. power cord (cigarette lighter adapter on one end)
- 1 Hex key set
- 1 Piece of Velcro (to attach hand controller to surface of your choice)

In order to fully assemble your mount, you will need the following separately sold items: pier, counterweights, and portable rechargeable battery pack. Several sizes and types are available for your selection. Many of these items will be discussed throughout these instructions.

Several additional options will help to enhance your observing experience: JMI computerized digital setting circles, and Santa Barbara Instrument Group ST-4 or ST-6 CCD Imaging camera/autoguider, polar axis telescope, and trays for your pier.

INTRODUCTION

We recommend that you familiarize yourself with the assemble and basic operation of the mount indoors. The temperature will be comfortable, the mosquitoes at bay, and you'll have enough light to see the illustrations and read the manual. Please take particular note of counterbalancing, use of the clutches and operation of the hand controller.

If you were to take a long exposure photograph with Polaris (often called the North Star) in the center of the field, you would discover that all stars seem to revolve around Polaris. This effect is due to the rotation of the earth on its axis. Motor driven equatorial mounts were designed to compensate for the earth's rotation by moving the telescope at the same rate and opposite to the earth's rotation. When the polar axis of the telescope is pointed at the celestial pole (polar aligned) as shown in the diagram to the right, the mount will follow (track) the motions of the sun, moon, planets, and stars. As a result, the object that you are observing will appear motionless as you observe through the eyepiece or take astrophotos.

For visual observation, a rough sighting of Polaris through the hole in the polar axis is

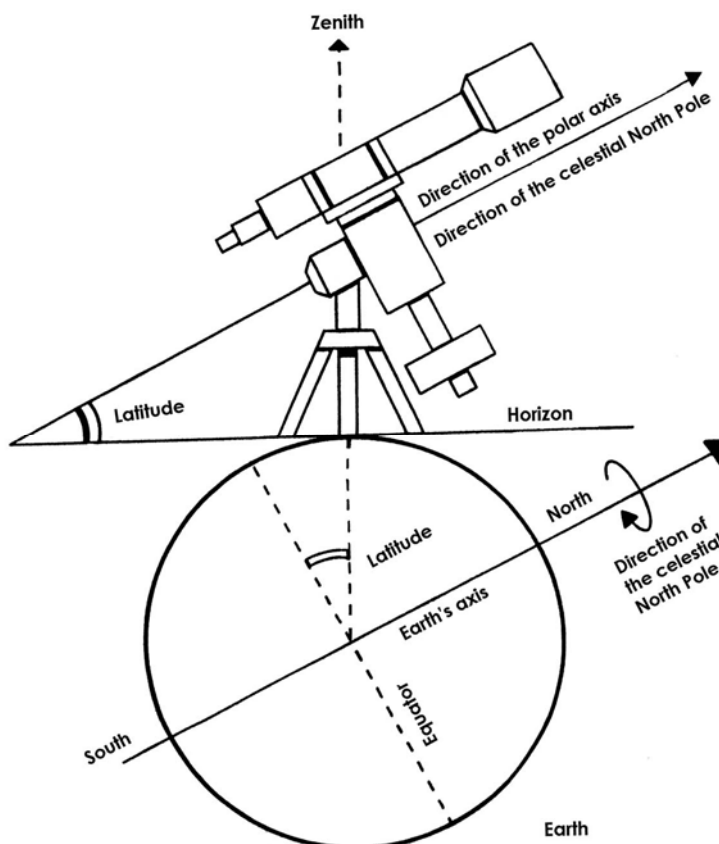

fine. However if astrophotography is your goal, accurate polar alignment is critical.

ASSEMBLY INSTRUCTIONS

Please read all instructions before attempting to set up your 1200 mount. The Model 1200 is very rugged; however, like any precision instrument, it can be damaged by improper use and handling. Please refer to the diagram below for an illustration of the mount. The parts are labeled so that we can establish common terminology.

The following terms and abbreviations may be used interchangeably in these instructions:

Polar axis = right ascension axis = R.A. axis = R.A. housing
Declination axis = Dec. axis = Dec. housing

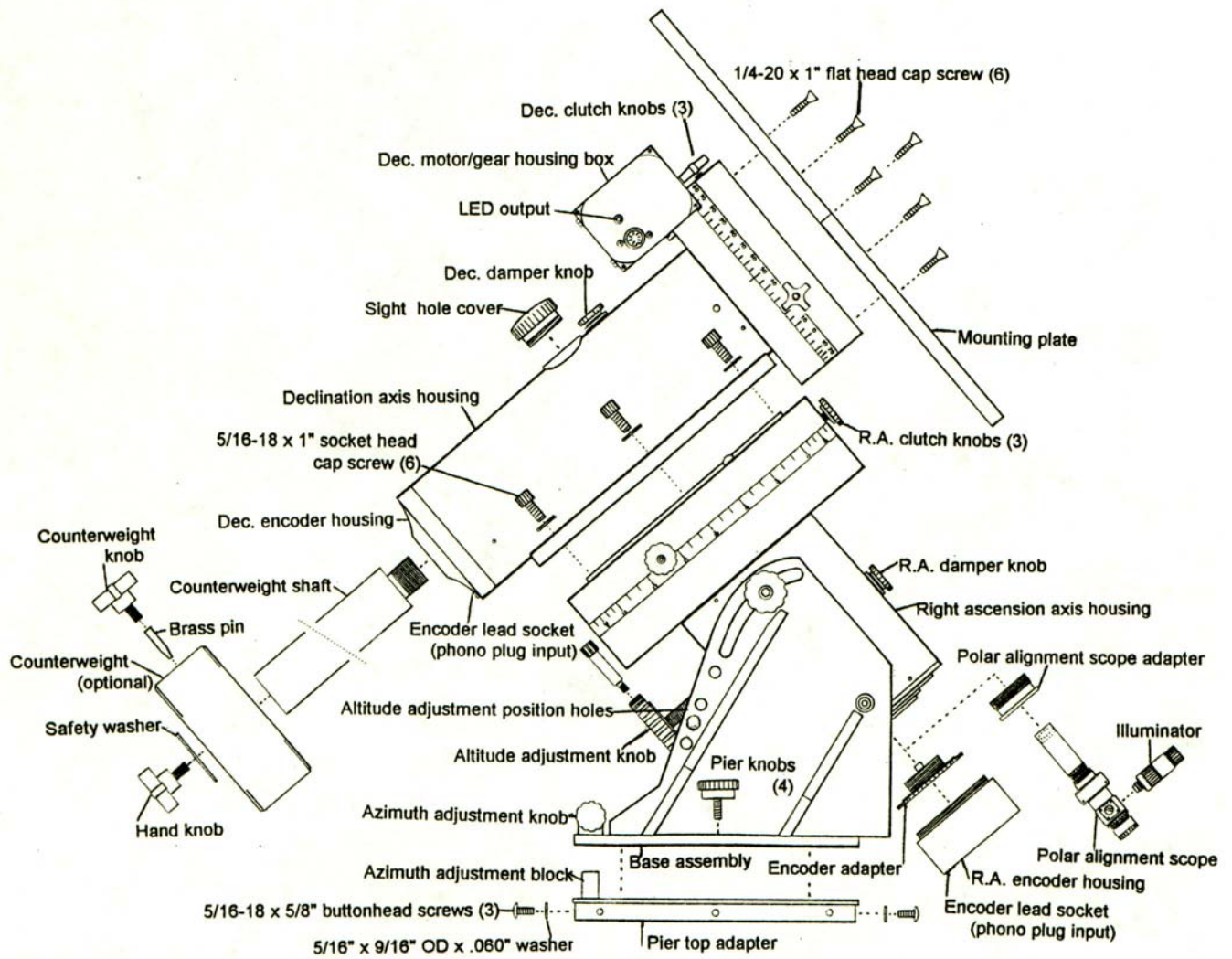

BEFORE YOU LEAVE HOME

Since most of us must set up our instruments in the dark, in the cold or while battling mosquitoes, a bit of preplanning and organization is important. There are a few simple things that can be accomplished in the comfort of your home before heading outside.

GROSS LATITUDE ADJUSTMENT: The latitude range of the 1200 mount is approximately 20-68 degrees. Since most astronomers typically observe within one latitude range, this adjustment is made just once, if at all. Prior to shipment, we preset the mount to your latitude range for your convenience. If you travel to another observing location, determine the latitude of your observing site and make the appropriate adjustment.

The four positions for the altitude adjustments have the following ranges:

- 55 degrees to 68 degrees latitude – top position
- 37 degrees to 59 degrees latitude – third position
- 28 degrees to 50 degrees latitude – second position
- 20 degrees to 37 degrees latitude – bottom position

How to change the position of the altitude adjuster bar

1. Use only the R.A. axis. DO NOT attempt to make these adjustments with the declination axis in place and certainly not with an instrument fully mounted.
2. Loosen both altitude-locking knobs about one turn.
3. Locate the side of the polar axis that does **not** have the motor/gear housing box. Loosen (about one turn) the polar axis pivot screw and altitude adjuster bar fixing screw on this side only. With your hand, push the polar axis upwards so that the altitude locking knobs are positioned at the top of the altitude slot (this is the maximum altitude position). Some resistance will be felt with this operation as you are pushing against the weight of the polar housing and the resistance of the remaining polar axis pivot screw (which has **not** been loosened).
4. Before attempting to move the altitude adjuster bar, you must tighten the altitude-locking knob on the motor/gear housing side. This will prevent any downward movement of the polar axis during positioning of the altitude adjuster bar.
5. While supporting the altitude adjuster bar, remove the two screws that support it on either side, but keep the two ends of the bar in contact with the side of the mount. Don't remove it completely. This tip is for your convenience.

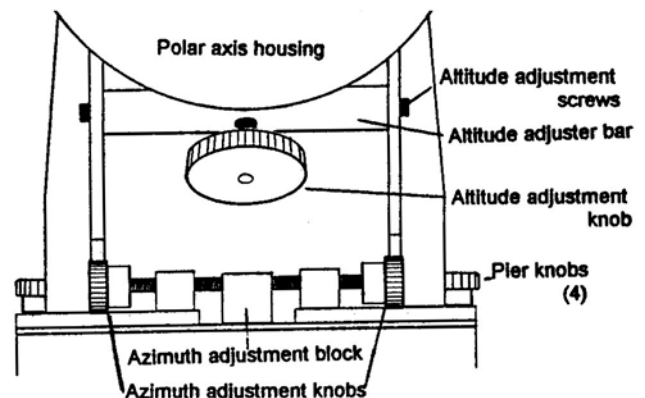
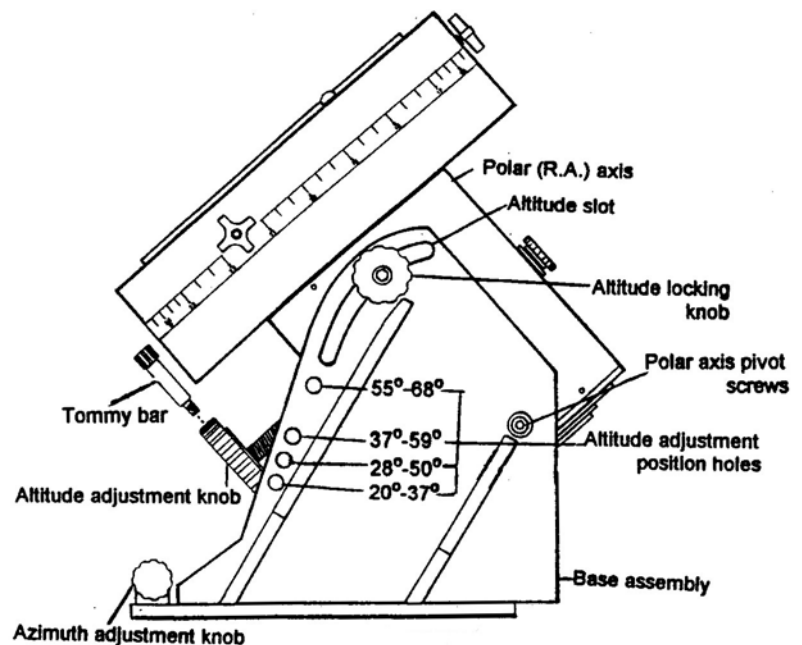

6. Guide (wiggle) the bar to the desired position, insert the screws in both ends and lightly tighten so that you still have some ability to move the bar.
7. Note that the altitude adjustment knob is attached to a threaded rod that travels through the altitude adjuster bar. Turn the knob so that the altitude adjuster bar is positioned approximately in the middle of the threaded rod. You should see about half of the threaded rod protruding from both sides of the altitude adjuster bar. This will allow you to move the mount fully within the altitude range.
8. At the end of the threaded rod mentioned in the last step, you will see a small brass altitude adjuster thrust pad. This is the part that will come in contact with the polar axis as you ease it back into position. Loosen the altitude-locking knob (motor/gear side) and lower the polar axis so that it rests comfortably on this pad. The threaded rod should be positioned at a right angle to the polar axis housing. Firmly tighten the altitude adjustment screws.
9. Turn the altitude adjustment knob to raise or lower the polar axis to your approximate observing latitude. Tighten the altitude locking knobs with finger pressure only. You do not need to tighten with the hex key.
10. Firmly tighten both polar axis pivot screws with the hex key.

ATTACH PIER ADAPTER TO PIER POST: If you purchased the pier from Astro-Physics, the pier top adapter of the 1200 is already attached to the top of the pier. If you are constructing your own pier or tripod, you will need to incorporate this part. The pier adapter was designed to fit into a 10" x 0.1" wall tube. Use three screws to attach this part. Note that the pier adapter has six 5/16"-18 holes in its side. With the Astro-Physics pier, you can choose a "north" or "south" facing pier leg by choosing the set of 3 holes that you prefer.

ASSEMBLE PIER

Begin by assembling the portable pier at the desired observing location. Note which direction is north.

1. Slide the three legs onto the nubs of the base and rotate the assembly so that one of the legs points toward north (or south, if this is your preference).
2. Place the pier tube on the base orienting the center azimuth block directly over the leg that is oriented to the north (or south).
3. Attach the tension rods. The turnbuckles should be drawn tight until the whole assembly is stiff enough to support your weight without movement.

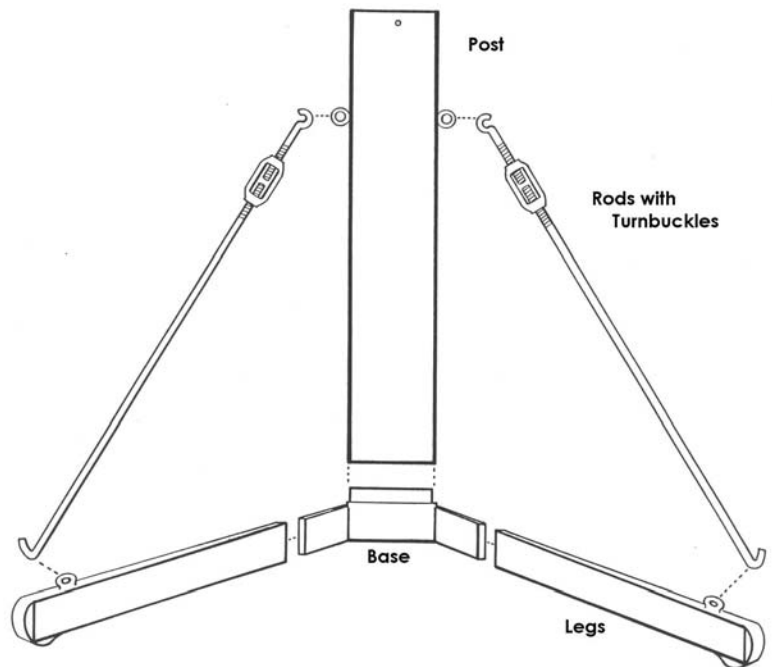

ASSEMBLE POLAR AXIS ASSEMBLY TO PIER OR TRIPOD

In order to track the motion of astronomical objects, the polar axis must be positioned so that an imaginary line drawn through the center of the axis points toward the celestial pole. At this stage of the assembly process, you want to position the mount so that it points roughly north.

1. Remove the four hand knobs on the pier top adapter and keep them close at hand.
2. Prior to lifting the polar axis assembly into place, turn the fine azimuth adjustment knobs so that the space between them is wide enough to allow the center azimuth block to fit easily between them. Ensure both pier top and polar axis assembly mating surfaces are clean and free of dirt.
3. Place the polar axis assembly onto the pier so that the center azimuth block fits between the fine azimuth adjustment knobs.

4. Move the base of the polar axis assembly so that the threaded holes of the pier top can be seen through each of the four slots.
5. Thread the four hand knobs loosely in place. You will tighten these later after polar alignment.

FITTING RIGHT ASCENSION ENCODER HOUSING

Since the polar alignment telescope and R.A. encoder adapter thread into the same location, you will need to switch back and forth between them as needed. This is good time to familiarize yourself with the removal and replacement of the R.A. encoder housing and encoder adapter.

If you use the JMI NGCMAX or Mini MAX Digital Setting Circles, you can use the “polar align” mode in these units instead of a polar alignment finder scope! Please continue to read these directions anyway since you may need to remove and reinstall the encoders if you use a polar alignment scope. The 1200 is always supplied with the encoders installed.

1. To remove: Unscrew R.A. encoder housing and R.A. encoder adapter.
2. To replace: Thread the R.A. encoder adapter into the end of your R.A. axis. (If your polar alignment scope is fitted, you must remove it first.) Use only moderate hand pressure to tighten the R.A. adapter since you will need to remove it again.
3. If you look at the black encoder housing, you will see the black encoder itself mounted at the rear of the housing. When this installation procedure is complete, the encoder shaft will insert into the center hole of the R.A. encoder adapter. This allows the encoder to read the motion of the R.A. shaft as the right ascension moves.
4. Now thread the R.A. encoder housing onto the R.A. axis housing. You may need to wiggle the encoder housing gently to engage the shaft of the encoder (located within the R.A. axis housing) with the hole in the center of the R.A. encoder adapter. Again, use moderate hand pressure, as you will need to remove this again.

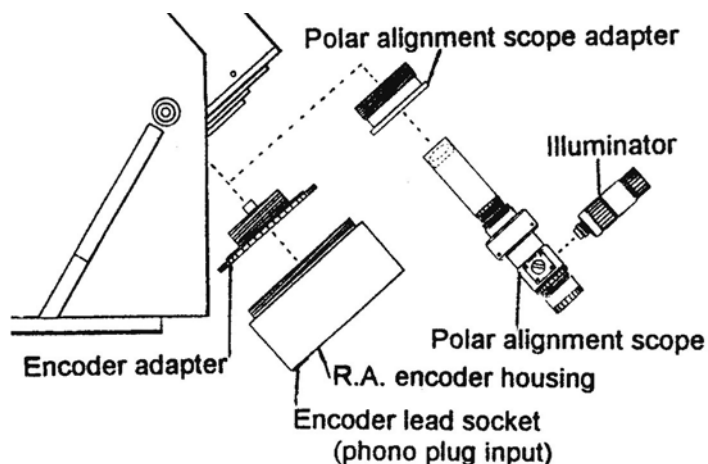

The hardware for your encoders is now installed. For actual set-up procedures for the “MicroMAX,” “MiniMAX” or “NGCMAX” digital computers, refer to the relevant operating manual.

If you remove the R.A. encoder frequently, you may wish to use a very tiny amount of auto grease on the mating threads.

ALTITUDE AND AZIMUTH ADJUSTMENTS – ROUGH POLAR ALIGNMENT for casual observation

Follow these instructions if you want to rough polar align your mount. If not, you may skip this section and move on to *Assemble Declination Axis*.

You may polar align your mount with the telescope and counterweights attached. This is important for accurate polar alignment. However the adjustment will require considerably more hand effort, so for rough polar alignment, you may wish to leave your scope and counterweights off.

For rough polar alignment, your goal is to sight the celestial pole when looking through the polar alignment sight hole in the center of the polar axis. You will need to make altitude (up/down) and azimuth (side to side) adjustments to the position of the mount.

1. Remove the R.A. encoder housing and encoder adapter as described in the previous section.
2. If you examine the polar axis assembly, you will see that the center of the R.A. shaft is hollow. The end of the R.A. axis is threaded to accept the polar axis telescope used for polar alignment. You do not need the polar alignment scope for this part of the process. If you have not done so already, loosen (1/2 turn) the four pier knobs.

NOTE: If you have already attached the Dec. axis, remove the sight hole cover and rotate the internal Dec. shaft by moving the top of the Dec. axis (or the mounting plate if it is attached) to reveal the sight hole that has been drilled into it. Now, you can look through the shaft to the other side.
3. **Azimuth adjustments:** Move the entire pier or tripod east or west until the mount is oriented approximately towards the pole (an imaginary line drawn through the hollow shaft). Use the two fine azimuth adjustment knobs, one on each side of the mount, to make fine adjustments in azimuth. You must back off the opposing azimuth knob in order to move the other knob in that direction. Please refer to the diagram on page 3.
4. **Altitude (latitude) adjustments:** Loosen the altitude locking knobs. Move the polar axis up or down with the large altitude adjustment knob located in the front of the polar axis assembly. The Tommy bar can be positioned in any of the threaded holes located in the altitude adjustment knob. Use this bar to help you turn the knob. Please refer to the diagrams on page 3. We have found that fine altitude adjustments also can be made by using the turnbuckle on the north leg of our pier, if used.
5. Continue your azimuth and altitude adjustments until you can sight Polaris in the polar alignment sight hole. At this point, you have achieved rough polar alignment, which may be sufficient for most casual visual observations. When the R.A. motor is engaged, it will compensate for the rotation of the earth and keep the target object within the eyepiece field of view. Your target object will slowly drift since polar alignment at this stage is only approximate. However, you can make corrections with your hand controller, as we will discuss later.
6. Tighten the altitude locking knobs by hand.
7. Tighten the pier knobs firmly by hand.

ASSEMBLE DECLINATION AXIS

1. Attach the declination axis assembly to the polar axis with the six 5/16-18x1" socket head cap screws and washers provided.
2. Thread the counterweight shaft into the Dec. axis.
3. Attach the cradle plate with the appropriate screws.
4. Remove the hand knob and safety washer from the base of the counterweight shaft. Add sufficient counterweights (10 or 18 lb. counterweights are available) to the declination shaft to balance the telescope you intend to use. Always use two hands to attach or move them on the shaft.
5. Reattach the hand knob and safety washer to the end of the declination shaft. This will help to prevent injury if someone accidentally loosens the counterweight knob.

NOTE: Firm tightening of the counterweight knob will not damage the surface of the counterweight shaft. The pin that tightens against the stainless counterweight shaft is constructed of brass. Likewise, a bronze sleeve that has been press fit into the center of the counterweight will prevent marring of the shaft as you move the counterweight up and down.

FINE POLAR ALIGNMENT – for astrophotography

Follow these instructions if you want to fine tune the polar alignment of your mount. If not, you may skip this section and move to *Operation of the Mounting*.

1. Methods for fine polar alignment:
 - Polar alignment telescope – The north celestial pole can be viewed through the polar axis with the optional polar alignment telescope included with your 1200 mount. Please read the instruction sheets "Polar Alignment Telescope and Illuminator."
 - JMI Digital Setting Circles – Please read the instructions included with your JMI unit.
 - Star Drift method – This is the most accurate method of polar alignment; however, it is also the most time-consuming. If you are planning long exposure astrophotos, we suggest that you use either the polar axis

telescope or JMI digital setting circles, then tweak the final polar alignment by star drifting. Please refer to the recommended reading list at the end of this manual.

2. Loosen the two altitude locking knobs and the four pier knobs. Refer back to the section on *Altitude and Azimuth Adjustments – Rough Polar Alignment*
3. Follow one of the methods of polar alignment mentioned above.
4. When polar alignment has been achieved, tighten the two altitude locking knobs and the four pier knobs. Please note that the polar axis pivot screws should have been tight throughout the fine polar alignment process.

OPERATION OF THE MOUNTING

R.A. and Dec. Damper knobs

The R.A. and Dec. damper knobs are not intended as axis locks. They should be tightened with light finger pressure, so that a slight resistance can be felt when pushing an unclutched axis by hand. This really adds to the “feel” at the end of the scope with the drives adjusted correctly.

R.A. and Dec. Clutch knobs

1. What do they do?

The three R.A. and three Dec. clutch knobs depicted in the diagram on page 2 have the function of connecting the R.A. and Dec. axes to their respective drive worm wheel gears. Their function is progressive, from no tension (axes free to move – as required during correct balancing of the telescope) to a completely “locked up” state.

2. How can you find out what they really do?

As shipped, all 1200 mounts have all three R.A. and Dec. clutch knobs firmly hand tightened. This will give you a good idea of the maximum tightness (clutch action) than can be achieved by hand effort alone. At this point, you must bear in mind that for optimum performance all three clutch knobs on each axis (R.A. or Dec.) should be tightened evenly with the same tension i.e. all three half tight, all three fully tight, etc.

In order to feel the effect of the clutch knobs, you may wish to partially assemble your mount. Fit together the R.A. and Dec. assemblies plus mounting plate and counterweight shaft. Do not put scope and counterweights on at this stage. With the above assembly (with the clutch knobs firmly hand tightened – “as shipped”), you can feel the amount of force needed to move each axis by hand. Grab each ends of the telescope mounting plate and move it with a backward and forward movement of the Dec. axis. You will feel considerable resistance to this motion. Perform the same operation on the R.A. axis by moving the counterweight shaft backward and forward. With a well-balanced telescope, the above tightness of the clutch knobs will be sufficient for all normal conditions of use.

Now, if you proceed to mount up and balance your telescope, you can “feel” what this resistance in R.A. and Dec. (movement backwards and forwards) is like when you make these motions from the eyepiece end of your telescope as you would during normal use when slewing (pushing) by hand to acquire an astronomical object within the field of view of your finder or scope

3. How tight can the clutch be and can you do any damage by pushing against them?

The maximum tightness of this clutch system is ½ turn (with a 5/32 allen key) further in than the tension you can achieve with the knobs by hand. You will see that each clutch knob has a 5/32 hex socket for tightening with an allen key. With this extra ½ turn on each clutch knob, the axis (axes) will be considered completely “locked up” and you should not attempt to push your scope by hand against this “locked up” resistance, or undue stress will be placed on the worm wheel/worm and bearings.

However, if you are undertaking a very long astrophoto exposure, it is advisable to increase the pressure on each clutch knob (with the 5/32 key) by about 1/4th turn on Dec. and 1/8th turn on R.A. You may safely slew the scope by hand with this tension, however you will notice considerably more effort is required to achieve movement. This is the absolute maximum tension that can be used for hand slewing. As a general rule, if you have a big scope (7” or 8” refractor) with all the accessories, you will need more clutch tension than a 5” or 6” scope.

Drive Test Knobs - You will notice in diagram 7 below the R.A. and Dec. drive test handles. These are NOT intended as manual control knobs for centering objects in the field of view. Please use the buttons of the dual axis hand controller to center objects in the eyepiece. Never, never attempt to turn these knobs manually.

These test knobs are used at the factory for initial setting of the worm wheel/worm mesh. Their main purpose for the end user is to give a quick visual verification of the worm drive motion (forward, reverse at 2x, 8x, and 16x). You can easily see the rotation of these test knobs especially at 8x and 16x speeds.

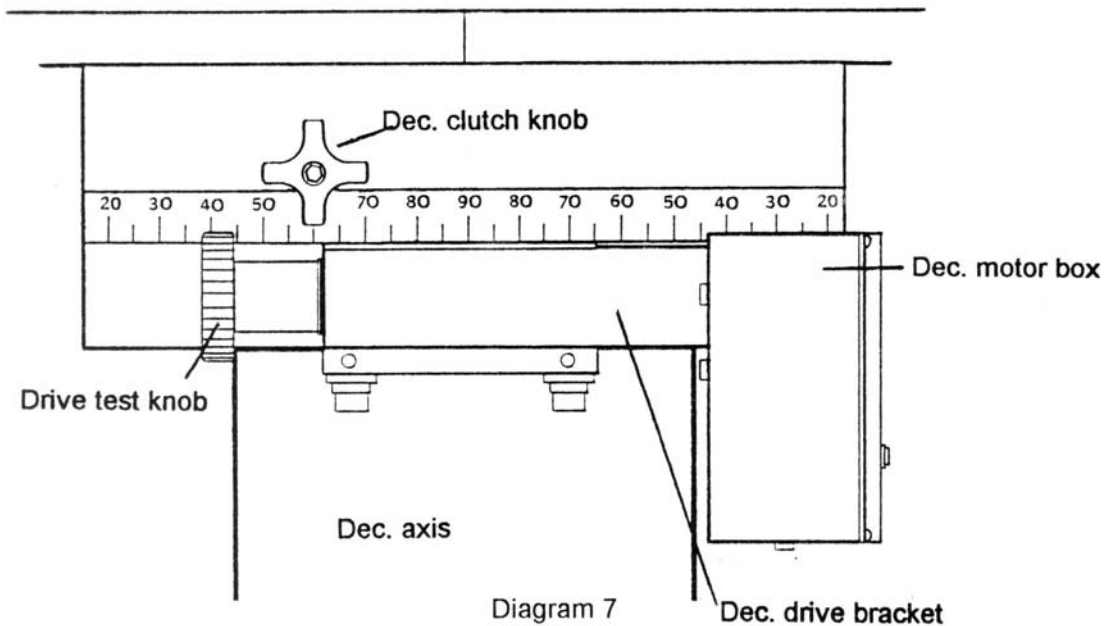

Balancing Your Telescope:

For proper operation, the telescope must be adequately counterbalanced. Start by balancing the tube assembly.

1. Tighten the three R.A. axis clutch knobs.
2. Loosen the three Dec. axis clutch knobs (about $\frac{3}{4}$ to 1 turn) so that the telescope moves freely about the declination axis. (Be careful because if your telescope is significantly out of balance, it may swing rapidly in the out of balance direction!)
3. Position the R.A. axis so that the counterweights are in their "lowest" position i.e. the declination axis assembly is in the meridian (this is the usual way that German equatorials are depicted, as shown in the diagram on page 2).
4. Loosen the tube mounting rings and slide the tube up and down for balancing. This is best done with the tube in the horizontal position.
5. The scope is balanced when it stays put (does not move) with the clutches loose and movement back and forth about the declination axis has the same feel in both directions.
6. Now, tighten the declination axis clutch knobs and position the telescope horizontal and the declination axis horizontal. The center of the counterweights is now the same height as the middle of the tube.
7. Loosen the R.A. clutch knobs. Again, be careful, because if your scope is significantly out of balance it may swing rapidly in the out of balance direction!
8. Move the counterweight(s) up or down to achieve balance in R.A. As mentioned before, movement back and forth about the R.A. axis should have the same feel in both directions.
9. Try to anticipate any balance problems due to the extra weight of diagonals, heavy eyepieces, finders, solar filters, etc. If the scope moves by itself, when the clutches are loose, then the scope is not fully counterbalanced adequately. A small amount of imbalance is permissible and indeed desirable.

OPERATION OF THE QUARTZ MICRO-DRIVE CONTROLLER

The push button controller contains all the circuitry for driving the two motors. The controller will be operational when attached to both the motors of the mount and a power source. There is no on-off switch.

A very accurate quartz clock specifically calibrated for the drive gear is an integral part of the controller. The calibration is made to the King sidereal rate, which compensates for atmospheric refraction over a large part of the sky. With this tracking rate, it is easier to maintain critical guiding at high power. For the most sophisticated tracking of celestial objects, the controller has a built-in provision for attaching a ST-4 or ST-6 CCD imaging camera/autoguider. Using the autoguider function, it is possible to take long exposure astrophotos totally unattended. You can walk away from the setup to enjoy other observing activities while your astrograph is in operation.

CABLES: Place the DC power cord into the phono plug outlet of the R.A. motor box. Plug the short length of the "Y" cable into the R.A. motor box and the long length into the Dec. motor box. Complete the cable assembly by joining the control box cable to the "Y" cable. The control box and motors are designed to work at 12 volts DC. Suggested power sources include: portable rechargeable battery pack, auto battery, or power inverter for 110 volts with a minimum output of 800ma.

DRIVE ROTATION: If you are operating the 1200 mount north of the equator, the HEM (hemisphere) switch must be set to "N". If south of the equator, set the switch to "S".

PUSH BUTTONS: The four red buttons are arranged so that the left and right buttons control the movement in right ascension, and the top and bottom buttons control the declination. This is the normal orientation of objects in the eyepiece field. If the star moves down when you push the "N" button, move the DEC REV (Dec. Reverse) switch to the opposite position. Pushing the right hand button "E" should cause the star to move to the right. If it moves to the left, move the R.A. REV (R.A. Reverse) switch to the other position. When properly set up, the controller buttons will cause the object to move according to your orientation at the eyepiece.

MODE SWITCH: There are three guiding modes (rates): a 2X guiding rate, an 8X and a 16X slew rate. The slew rates are for positioning objects in the field; the guiding rate is for fine-guiding at high powers during astrophotography. Move the switch to select the mode that you prefer.

SELECT BUTTON: The control box has three drive rates to choose from: SID (sidereal), SOL (Solar), and LUN (lunar). Select the position appropriate for the object under observation.

King Sidereal: Tracking rate for observing planets, stars, galaxies, and other distant objects.

Solar: Tracking rate for observing the sun.

Lunar: Tracking rate for observing the moon.

LED KNOB: There is an LED output available on the 1200 Dec. axis motor housing as shown in the diagram on page 2. You may insert your LED reticle to this plug. Brightness can then be controlled using the MIN to MAX (minimum to maximum) setting of the LED knob.

AUTOGUIDER CONNECTION: If you own a Santa Barbara Instrument Group (SBIG) ST-4 or ST-6 Star Tracker/Imaging system, connect it to the controller via the 9-PIN connector. Call Astro-Physics to purchase a separate cable for this connection, or we can add the correct connector to the cable supplied by SBIG.

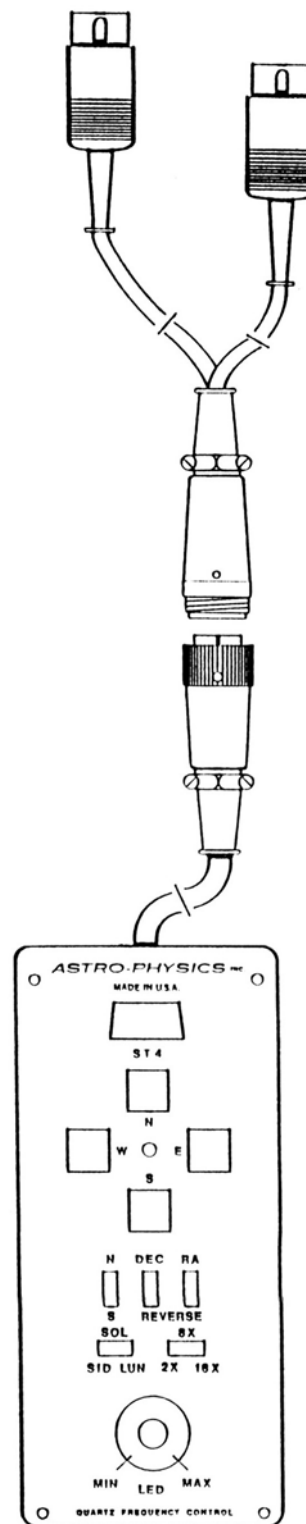

GUIDING YOUR ASTROPHOTOS

The natural tendency of an astrophotographer is to push the directional button of the controller in the direction he or she wants the guide star to move until the star has centered itself in the guiding reticle. This method often results in overshooting the center of the reticle since the reaction time to let go of the button is often too late. By the time the gears in the drive motor have reversed and are driving again at the normal guiding rate, the star has moved past the center of the reticle. Then the opposite button is pushed to move the guide star back in the opposite direction toward the center and the same overshooting may occur.

The proper way to guide (and this will apply to almost any commercially available mounting) is to pulse your correction, much like the SBIG ST-4 does in its auto-guiding operation. Pulse the button for only a fraction of a second and note the new position of the guide star. If it has not moved far enough, pulse it again. Normally, it takes only one or two pulses to re-center the star in declination, since this drift will be extremely slow. This assumes that mount was properly polar aligned. When the star need to be reversed, it rarely takes more than 5 to 8 pulses in rapid succession, each lasting less than 1/10 second to get the star to re-center in the reticle. This same method should be used to keep the star centered in right ascension also. With some practice, you will be able to keep the guide star perfectly in declination with only an occasional pulse every 5 or 10 minutes while concentrating almost entirely on the right ascension drift.

MOUNT MAINTENANCE AND ALIGNMENT

Under normal operating conditions, minimal maintenance is required. Every 12 months the clutch knobs (3 for Dec. and 3 for R.A.) should be removed and 1 or 2 drops of light oil (3-in-1 household oil) should be put in the exposed hole. If the R.A. and Dec. axes are bolted together for a long time in outside conditions (i.e. in a permanent observatory) then the mating surfaces should be lightly oiled or greased – if you expect to get them apart again after 10 years.

Your 1200 is a precision instrument with very accurate worm and wheel adjustments. Please be careful if you place the mount on a flat surface, i.e. the ground or trunk of your car. The gear alignment may be affected if the R.A. and Dec. motor/gear box assemblies sustain undue lateral force. This is true of any fine instrument. We suggest that you transport and store the mount in a case or in a well-padded box

NOTE: If your battery runs low, the declination motors will stop first, though the R.A. will continue to drive until the power is drained.

If any problems occur, please don't hesitate to contact Astro-Physics for assistance.

ASTRO-PHYSICS INC
11250 Forest Hills Road
Rockford, IL 61115
Telephone: (815) 282-1513
Fax: (815) 282-9847
www.astro-physics.com

Recommended reading list from our staff:

The Backyard Astronomer's Guide, Terence Dickinson and Alan Dyer, Camden House Publishing, 1991. The authors, both former editors of *Astronomy* magazine, offer practical insight into astronomical equipment, finding your way around the sky, polar alignment, using setting circles, and astrophotography. This book provides excellent explanations and is well organized and illustrated.

All About Telescopes, Sam Brown, Edmund Scientific Company, 1975. This has excellent information regarding the principles of mount construction and operation, using setting circles, eyepiece projection, etc. Illustrations and formulas galore. Many of the instruments pictured are outdated, however the underlying principles are timeless.

Norton's 2000.0 Star Atlas and Reference Handbook, edited by Ian Ridpath, J. Wiley Publishers, 1989. Star maps, information regarding polar alignment of German equatorials and observing techniques.

INSTALLATION OF ENCODERS AND ENCODER HOUSINGS – 1200 MOUNT 1200ENC (purchased separately)

PART LIST

- 1 Right Ascension (R.A.) Encoder housing (black anodized)
- 1 Declination (Dec.) Encoder housing (black anodized)
- 1 R.A. Axis Adapter (clear anodized – silver colored), labeled R.A.
- 1 Dec Axis Adapter (clear anodized – silver colored), labeled Dec.

To install your encoders, first remove the telescope from your mount. Remove your declination counter weight(s) and declination counterweight shaft.

FITTING DECLINATION ENCODER HOUSING

If the encoders were purchased with the 1200 mount, it is likely that the declination axis adapter and encoder housing have already been installed. No further action will be required, as this encoder will remain in place.

1. If the encoders were purchased separately, the silver-colored Dec. axis adapter may be inside the black Dec. axis encoder housing. If it is, remove it now.
2. Locate the counterweight shaft adapter (the black anodized part that the counterweight threads into) on the Dec. axis. When we assembled the mounts, we threaded this on rather tightly, so you will need some extra leverage to remove it. Locate the hole that was drilled into the part and find some object that you can insert. We suggest that you use one of your allen head wrenches that is wrapped in masking tape so that you do not mar the finish of the part. Since you may need to apply a good deal of force, it may be easiest to do if the mount is on the pier so that it won't move.
3. Thread the Dec. axis adapter into the end of your Dec. axis. Final tightening should be done with firm hand pressure. Normally the Dec. axis adapter will not be removed.
4. If you look into the black encoder housing, you will see the encoder itself mounted at the rear of the housing. When this installation procedure is complete, the encoder shaft will insert into the center hole of the Dec. axis adapter. This allows the encoder to read the motion of the declination shaft as the declination axis moves.
5. Thread the Dec. encoder housing onto the Dec. axis housing of the 1200 mount. You may need to wiggle the encoder housing gently to engage the shaft of the encoder with the hole in the center of the Dec. axis adapter. When the threading is complete, tighten up with firm hand pressure (or insert your special "tool" from above and tighten firmly) since normally this encoder housing will not be removed.
6. The counterweight shaft may now be rethreaded into the rear of the Dec. encoder housing.

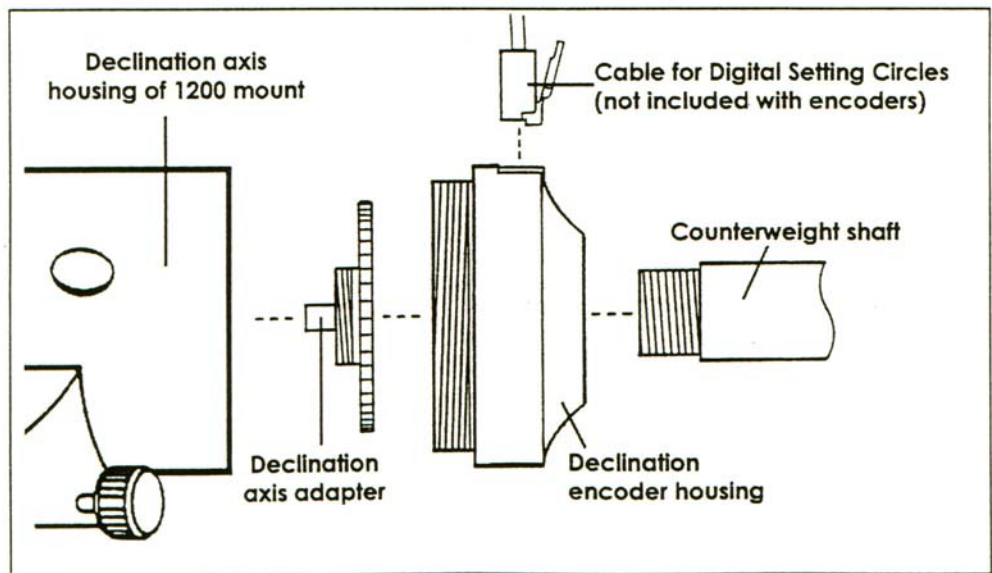

FITTING RIGHT ASCENSION ENCODER HOUSING

If the encoders were purchased with the 1200 mount, it is likely that the right ascension axis adapter and encoder housing have already been installed. Please continue to read these directions since you may need to remove and reinstall the encoders if you use a polar alignment scope. Since the polar axis telescope and R.A. axis adapter thread into the same location, you will need to switch back and forth between them as needed. If you use the JMI NGC MAX or Mini Max Digital Setting Circles, you can use the "polar align" mode in these units instead of a polar alignment scope.

1. If the encoders were purchased separately, the silver-colored R.A. axis adapter may be inside the R.A. axis encoder housing. If it is, remove it now.
2. Thread the R.A. axis adapter into the end of your R.A. axis. If your polar alignment scope is fitted you must remove this first along with the polar alignment scope adapter. Use moderate hand pressure to tighten the R.A. adapter since you may need to remove it to install the polar axis telescope at a later time.

3. If you look into the black encoder housing, you will see the encoder itself mounted at the rear of the housing. When this installation procedure is complete, the encoder shaft will insert into the center hole of the R.A. axis adapter. This allows the encoder to read the motion of the R.A. shaft as the right ascension axis moves.

4. Now thread the R.A. encoder housing onto the R.A. axis housing. You may need to wiggle the encoder housing gently to engage the shaft of the encoder (located within the R.A. axis housing) with the hole in the center of the R.A. axis adapter. Again, use moderate hand pressure as you may wish to remove that at some time.

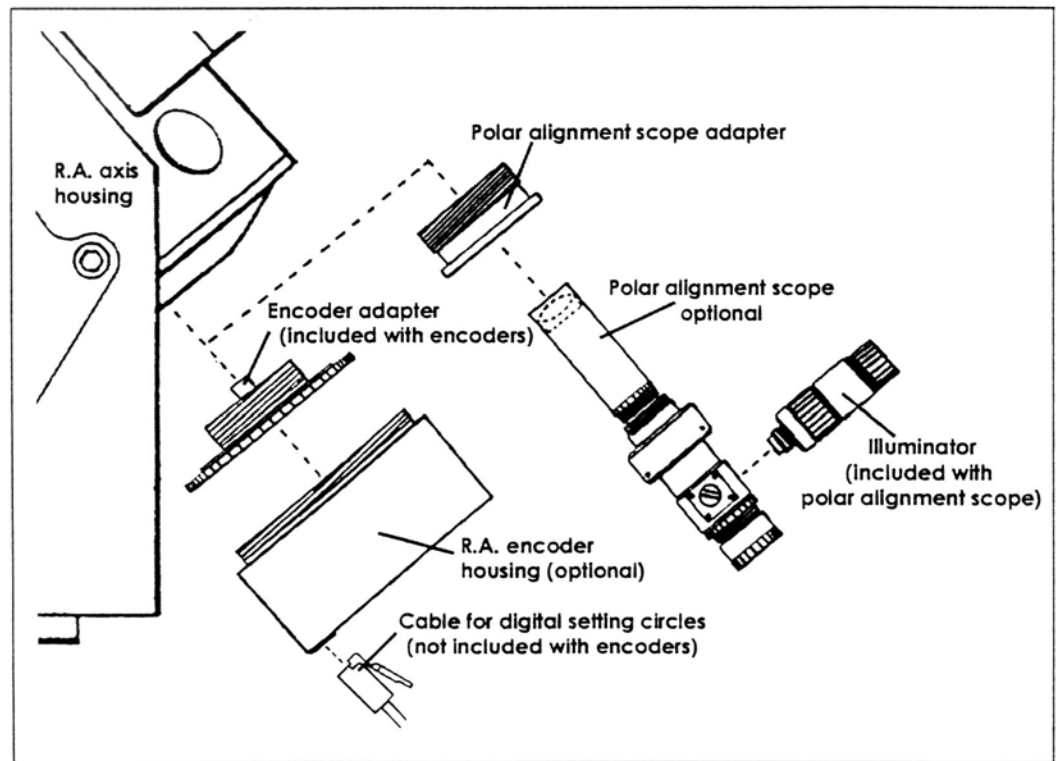

Diagram 14

5. The hardware for your encoders is now installed. For actual set-up procedures for Micro MAX, Mini MAX or NGC MAX, digital readouts refer to the relevant operating manual from the manufacturer. We provide some startup tips in our instruction sheet entitled "Using JMI Setting Circles".

PERIODIC MAINTENANCE

If you remove the R.A. encoder frequently, you may wish to use a very tiny amount of auto grease on the mating threads.