

# ASTRO

*State-of-the-Art Instruments*



# PHYSICS

*for Discriminating Astronomers*

## 1600GTO German Equatorial Mount with GTOCP4 Servo Motor Drive

Mounts Shipped  
Starting in  
January 2024



Keypad Optional

Astro-Physics, Inc.  
11250 Forest Hills Road  
Machesney Park, IL 61115  
Telephone: 815-282-1513  
Fax: 815-282-9847  
support@astro-physics.com  
www.astro-physics.com

# **ASTRO-PHYSICS**

## **1600GTO GERMAN EQUATORIAL WITH GTOCP4 SERVO MOTOR DRIVE**

ABOUT THIS MANUAL (JANUARY 2024)	4
PART LISTS	5
1600GTO	5
1600GTO-AE	5
1600GTO-AEL	5
RECOMMENDED AND OPTIONAL ACCESSORIES	6
Recommended Accessories	6
Optional Accessories	6
MECHANICAL SPECIFICATIONS	7
INTRODUCTION	8
Why Polar Alignment is Important	8
ASSEMBLY DIAGRAM	9
NOW IT'S TIME TO SET UP!	10
Additional Handy Tools	10
AT YOUR OBSERVING SITE	11
Assemble Pier (purchased separately)	11
Attach Polar Axis Assembly to Pier	11
Latitude Adjustment for 1600GTO German Equatorial Mounts	12
Special 90 Degree Alt-Azimuth Position	13
ASSEMBLY INSTRUCTIONS	14
Assembly of R.A. and Dec. Axes	14
Assembly Procedure	14
Disassembly Procedure	15
CABLE MANAGEMENT	16
Preparation	16
The Basics	16
The Specifics	16
Routing Cables if You Plan to Use the Cable Router Insert When Using the Polar Scope	17
Routing Cables if You Don't Plan to Use the Cable Router Insert	18
ATTACH MOUNTING PLATE	19
Fixed Mounting Plate Options	19
Losmandy D-Style Compatible Saddle Plate	20
Side-by-Side D-Style Option	20
Astro-Physics P-Style Compatible Saddle Plate	21
Side-by-Side P-Style Option	21
ATTACH COUNTERWEIGHT SHAFT AND COUNTERWEIGHTS	22
ATTACH MOUNTING RINGS AND SCOPE	22
UNDERSTANDING THE R.A. AND DEC. CLUTCH KNOBS	23

<b>BALANCING THE TELESCOPE</b>	<b>24</b>
Preliminary Balancing	24
Precision Balancing	24
<b>BALANCING SIDE-BY-SIDE</b>	<b>26</b>
<b>ALTITUDE AND AZIMUTH ADJUSTMENTS – ROUGH POLAR ALIGNMENT</b>	<b>28</b>
<b>POLAR ALIGNMENT OPTIONS – FINE POLAR ALIGNMENT</b>	<b>29</b>
Methods for fine polar alignment	29
Making Precise Altitude and Azimuth Adjustments	30
Fine Altitude Adjustment	30
Tips for Adjusting the Altitude	30
Fine Azimuth Adjustment	31
Precision-Adjust Rotating Pier Base with Azimuth Bearing	31
Using Software to Improve Pointing Accuracy	31
<b>MISCELLANEOUS ITEMS</b>	<b>32</b>
Bubble Level and Lanyard Post	32
Reference Orientation Lines	32
Warning for Dec. Servo Cable	32
<b>ORTHOGONALITY CORRECTION</b>	<b>33</b>
<b>1600GTO-AE AND 1600GTO-AEL ABSOLUTE ENCODERS</b>	<b>34</b>
Additional Parts Included with the Absolute Encoders	34
Absolute Encoder Cable Connections	34
Benefits of Absolute Encoders Summary	34
<b>WHAT IS MEANT BY “INITIALIZATION”?</b>	<b>36</b>
<b>QUICK START SUMMARY – NEW INSTALLATIONS USING KEYPADS</b>	<b>37</b>
<b>QUICK START SUMMARY – NEW INSTALLATIONS USING COMPUTERS</b>	<b>37</b>
<b>WHAT IF I GET LOST?</b>	<b>38</b>
<b>SLEWING YOUR MOUNT IN BELOW FREEZING TEMPERATURES</b>	<b>39</b>
<b>AUTO-ADJUSTING GEARBOX - NO MORE WORM MESHING!</b>	<b>40</b>
Checking and Adjusting the Gearbox Backstops in R.A. and Dec.	40
What to do if you believe that there is a backlash in the gearbox	41
<b>REMEMBER THESE TIPS</b>	<b>42</b>
<b>MOUNT CARE, CLEANING AND MAINTENANCE</b>	<b>43</b>
Care	43
Cleaning and Touch-up	43
Counterweight Appearance	43
Routine Mount Maintenance	43
Worm Wheel Maintenance	43
<b>TROUBLESHOOTING, TIPS AND SUPPORT</b>	<b>44</b>
Troubleshooting and Tips	44
Additional Support	47

APPENDIX A: PRE-DEFINED PARK POSITIONS	48
APPENDIX B: DRIFT ALIGNMENT – RA CORRECTION METHOD	50
APPENDIX C: ROLAND’S GTO QUICK STAR DRIFT METHOD - 2020 VERSION	51
APPENDIX D: DECLINATION AXIS BACKLASH TESTS	52
PulseGuide™	52
Dec Backlash Test 1	52
Dec Backlash Test 2	52
After Running Tests 1 and 2	53
Dec Backlash Test 3	53
MaxImDL™	53
Step 1	53
Step 2	53
Step 3	53
APPENDIX E: MOUNTING PLATE FASTENER CHART	54

# ABOUT THIS MANUAL (JANUARY 2024)

This version of the 1600GTO Manual was prepared for the production run of mounts that began shipping in January of 2024. Most of the information in this manual is applicable to all 1600GTO mounts that have been produced.

You should also note that this manual is actually one component of a multi-document system. This manual deals primarily with the mechanical features and physical operations of your mount. Please consult these other manuals for in-depth information regarding the electronics, keypad controller and software.

- GTO Servo Motor Drive System , Model GTOCP4 manual, printed copy sent with the mount and on the USB thumbdrive.
- Astro-Physics Command Center (APCC-PRO) Help File, be sure to save a copy of the PDF when you install APCC.
- GTO Keypad manual, printed copy provided if you purchased a Keypad with your mount.

All of these manuals can be accessed from the Support or Software Updates tab of our website. We highly recommend that you check out the Technical Support Section of our Web site for the latest information and for future updated versions of this and the other manuals.

**Note: Some photos in this manual may differ slightly from the current mounts, control boxes, and/or accessories that are shipping, or equipment that you have from an earlier production run.**

A final note and an apology to our friends in the southern hemisphere. Many of the instructions in this manual are written entirely from the point of view of those of us in the northern hemisphere. Since descriptive terms like left and right are meaningless without a defined point of reference, we tend to use east and west to avoid ambiguity. The east and west sides of a German equatorial mount are, of course, reversed in the southern hemisphere. At one point, our thought was to always use phrases like the following: "... on the east side (west side in the southern hemisphere) ..." This quickly became cumbersome and made the text more difficult to read. For simplicity, we decided to leave many of the explanations in their northern hemisphere framework. To our southern hemisphere friends: *We love you no less and apologize for this unintended slight.* We know, however, that you are all smart enough to make the necessary translation to "down under" appropriate instructions. Thank you for your understanding.

## PLEASE RECORD THE FOLLOWING INFORMATION FOR FUTURE REFERENCE

Mount Serial Number: \_\_\_\_\_

GTOCP4 Serial Number: \_\_\_\_\_

Keypad Serial Number: \_\_\_\_\_

Purchase Date: \_\_\_\_\_

# PART LISTS

## 1600GTO

- 1 Polar Fork / Right Ascension Axis (R.A.) Assembly
- 1 Declination Axis (Dec.) Assembly
- 1 Dec. Top Plate (S1600DTP)
- 1 GTO Servo Control Box (GTOCP4)
- 1 22" x 1.875" Stainless Counterweight Shaft (M12601-E) with machined Safety Stop (M12676)
- 1 R.A. Cable Router Insert (M16145-A)
- 1 Mount to GTOCP4 Cable (CABGTOR19)
- 1 D.C. power cord set - 6' cable with power pole connectors (CABPP6), 18" cable with cigarette plug (CABPP18C) and 18" cable with ring connectors (CABPP18R) and clip (FPCLIP)
- 1 15' Straight-through Serial Cable (CABSER15)
- 1 Hex key Set
- 10 3/4" x 8" Velcro Cable tie wraps
- 1 USB thumbdrive containing: *PEMPro*™ v3 Software (written by Ray Galak of Sirius Imaging) and PDFs of manuals Instruction Manuals, and various useful software utilities.  
Fasteners:
  - (6) 1/4-20 x 3/4" SHCS (for safety backup of dovetails)
  - (7) 5/16-18 x 5/8" SBHCS (pier adapter) (6 + 1 extra)
  - (7) 5/16" flat washers (pier adapter)

## 1600GTO-AE

- All items listed above for the 1600GTO, plus:
- 1 R.A. and Dec. RESA Ring Assemblies, installed
  - 1 R.A. and Dec. Readhead Assemblies, installed
  - 1 Cable from GTOCP4 Control Box to Interface at rear of the R.A. axis (CAB16AE)
  - 1 Screw driver, 1/8" flat (FSDF18)

## 1600GTO-AEL

All items listed above for the 1100GTO-AE, except that the Readheads are the Extended Temperature version.

# RECOMMENDED AND OPTIONAL ACCESSORIES

In order to fully assemble your mount, you will need some of the following items sold separately. Many of these items will be discussed throughout these instructions.

## Recommended Accessories

- **10" O.D. pier:** Astro-Physics piers are available in several height versions.
- **Counterweights:** 5 lb. (5SCWT), 10 lb. (10SCWT), 18 lb. (18SCWT) and 30 lb. (30SCWT188) are available.
- **Regulated Power Supply (110V AC to 12V DC converter):** We recommend the Variable-volt, 25-amp supply (PSVPW25A) for heavier loads and colder weather. The mount should have its own power supply.
- **Portable rechargeable 12-volt battery pack:** Several sizes and types are available from a variety of vendors. Be sure that your battery pack can supply adequate power for an entire observing session! Please refer to power requirements under Features and Specifications on next page. We recommend having separate batteries – one for the mount and one or more for all other accessories: camera, computer, dew removers etc. You may wish to consider:
  - **CP4 Powerpoles to Alligator Clips (CABPPAL)** - For connecting the CP4 Power Cable to battery terminals.
  - **DC Inline Watt Meter and Power Analyzer (CABPPWM)** - To monitor your power consumption.

## Optional Accessories

- **Optional GTO Keypad controller** with 15' coiled cable. Hand-held computer to operate the mount without a PC and additional software.
- **9" Counterweight Shaft Extension (M12675):** For heavier loads.
- **Autoguiding accessories:** Various guiding configurations can take advantage of the 1600GTO's autoguider port. The autoguider port receptacle (RJ-11-6) uses the industry standard SBIG ST-4 wiring setup.
- **Pier accessory trays and support bars:** Accessory Tray (TRAY10) and/or Eyepiece Accessory Trays (TRAY10H) with Bi-Level (TRAYSB) or Single Level (TRAYSB1) Support Bars. Keep things close at hand.
- **1600 Flat Surface Adapter (1612FSA):** For attaching the 1600GTO to your own custom pier or tripod.
- **1600 Flat Surface Adapter with Flat Pier Plate (1612FSA-FP):** For attaching the 1600GTO to the Advanced Telescope System (ATS) pier, or to your own custom pier or tripod when a flat pier plate is needed.
- **Polar Alignment Scopes:** AP Right-Angle Polar Alignment Scope (RAPAS) and Losmandy Polar Alignment Scope (PASILL4-179) – Many users find a polar alignment scope useful for zeroing in on the pole quickly, particularly with telescopes that are not orthogonal to the mount. This is particularly useful for portable setups.
- **DC Inline Watt Meter and Power Analyzer (CABPPWM)** - To monitor your power consumption.
- (PASILL4-179) – Many users find a polar alignment scope useful for zeroing in on the pole quickly, particularly with telescopes that are not orthogonal to the mount. This is particularly useful for portable setups.

For a complete listing of our 1600GTO accessories, visit our Web site – [www.astro-physics.com](http://www.astro-physics.com).

## MECHANICAL SPECIFICATIONS

Construction	All CNC machined aluminum bar stock, stainless steel, brass; stainless steel fasteners
Finishing and Assembly	Every part is hand-finished and inspected. All assembly is done by hand, by highly skilled mount assembly staff.
Worm wheel - R.A. & DEC.	10.3" (262 mm), 225 tooth aluminum
Worm gear - R.A. & Dec.	1.22" (31 mm) diameter, special low-wear alloy
Axis shaft - R.A. & Dec.	3.74" (95 mm) diameter
Shaft axis bearings - R.A. & Dec.	5.71" (145 mm) diameter
Latitude range	0 to 78 degrees and 90 degrees for Alt-Az
Azimuth adjustment	Approximately 13 degrees ( $\pm 6.5$ degrees from center)
Counterweight shaft	1.875" (47.6 mm) diameter x 22" (559 mm) long, includes large machined safety stop knob; weight: 17.2 lb. (7.8 kg). Optional 9" (229 mm) shaft extension available.
Weight of mount	R.A. axis / polar fork: 63.7 lb. (28.9 kg) Dec. axis: 40.0 lb. (18.1 kg) Dec. top plate 3.0 lb. (1.4 kg)
Capacity of mount	Approximately 220 lb. (100 kg) scope and accessories (not including counterweights), depending on length. Recommended for refractors up to 250 mm, 18-20" Cassegrains, Ritchey-Chrétiens and CDKs. These are only guidelines. Some telescopes are very long for their weight or heavy for their size and will require a larger mount. Remember also that imaging requirements are more rigid than visual observation.
Instrument mounting interface	Reference the "Attach Mounting Plate" section of the manual.
Pier adapter base	9.775" (248.3 mm) diameter. The base is an integral part of the mount and azimuth adjuster.

***For a complete listing of the servo control, power, and periodic error specifications, please see the GTO Servo Drive System Manual.***





# INTRODUCTION

The 1600 German equatorial was designed to meet the needs of the advanced observer who requires a mount with maximum strength and rigidity and minimum weight. The excess material in both axes has been carved out while retaining a heavily ribbed structure for internal strength and rigidity. A unique dovetail was machined into the mating surfaces of the R.A. and Dec. axes and also between the Dec. axis and the Dec. axis Top Plate. This feature allows quick and easy assembly in the field without any tools.

The DC servo motor drive with GTO computer system, the optional keypad with its digital display screen, and the included AP V2 ASCOM Driver and *PEMPro*<sup>™</sup> v.3.x software all combine to offer extraordinary sophistication for today's observer. Whether you enjoy visual astronomy exclusively or plan an aggressive astrophotography or CCD imaging program, this mount will allow you to maximize your night out under the stars.

The advanced, optional keypad features allow you to slew automatically to objects in a wide range of databases as well as any R.A./Dec. or Alt./Az. coordinate. A large selection of common names for stars and other objects makes your selection a snap. The rapid slew rate of 5 degrees per second (1200x) allows you to locate objects very quickly and accurately. You will be very pleased with the intuitive operation of this keypad. There are no complicated sequences of keystrokes to remember. It is so easy to use that even if you don't use it for a few months, you will feel at home with the keypad very quickly.

The keypad is only one way of controlling the versatile Astro-Physics GTO Servo System. From its very conception, the servo controller was designed to work with any software that was written to use our published command set. We do not lock you into any proprietary software or mandatory "additional" equipment. To increase the versatility of all our mounts, we have developed and now fully support a V2 ASCOM Driver for use with all ASCOM client software.

As mentioned above, we also include a full version of *PEMPro*<sup>™</sup> (Periodic Error Management Professional) v.3.x (latest version) for you to enhance your control and performance options. As an added bonus, all 1600GTO mounts will come pre-loaded with the custom-fitted *PEMPro*<sup>™</sup> corrections from our extensive individual testing that is performed on each and every mount. While the native periodic error of your 1600GTO will be 5 arcseconds or less, you can reduce it even further to maximize performance without auto-guiding. These software control products are detailed later in the manual.

In addition to everything outlined above, the 1600GTO's control and performance options will be greatly enhanced by the Astro-Physics Command Center (APCC). APCC fully addresses all the capabilities of the 1600GTO, and adds enhancements not currently available in the keypad or in any other software.

The 1600 is equally at home in a permanent observatory or as a portable mounting for remote star parties thanks to the ease with which the two axes come apart. This is the perfect mount for a large refractor, Newtonian, Cassegrain or astrograph.

In order to maximize your pleasure on your first night out, we recommend that you familiarize yourself with the assembly and basic operation of the mount indoors. The temperature will be comfortable, the mosquitoes at bay, and you'll have enough light to see the illustrations and read the manual. Please take particular note of counterbalancing, use of the clutches and operation of the keypad controller.

## Why Polar Alignment is Important

Polar alignment permits accurate R.A. movement in order to compensate for the Earth's rotation.

If you were to take a long exposure photograph with Polaris (often called the north star) in the center of the field, you would discover that all stars seem to revolve around Polaris. This effect is due to the rotation of the earth on its axis. Motor-driven equatorial mounts were designed to compensate for the earth's rotation by moving the telescope at the same rate and opposite to the earth's rotation. When the polar axis of the telescope is pointed at the celestial pole (polar aligned) as shown in the diagram at right, the mount will follow (track) the motions of the sun, moon, planets and stars. As a result, the object that you are observing will appear motionless as you observe through the eyepiece or take astrophotos.

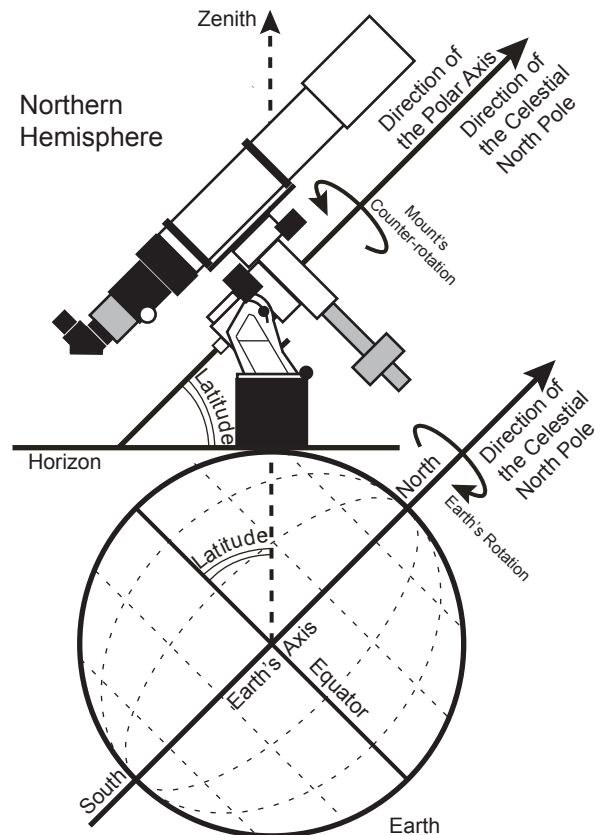

# ASSEMBLY DIAGRAM

The following terms and abbreviations are used interchangeably in these instructions:

Polar axis = right ascension axis = R.A. axis = R.A. housing

Declination axis = Dec. axis = Dec. housing

Please read all instructions before attempting to set up your 1600GTO mount. The model 1600GTO is very rugged; however, like any precision instrument, it can be damaged by improper handling. Please refer to the diagram below for an illustration of the mount. The parts are labeled so that we can establish common terminology. Pay particular attention to the section regarding joining and separating the R.A. and Dec. axes as this is unique to this mount. It is important to note the need to connect and disconnect the Dec. Servo Cable internally.

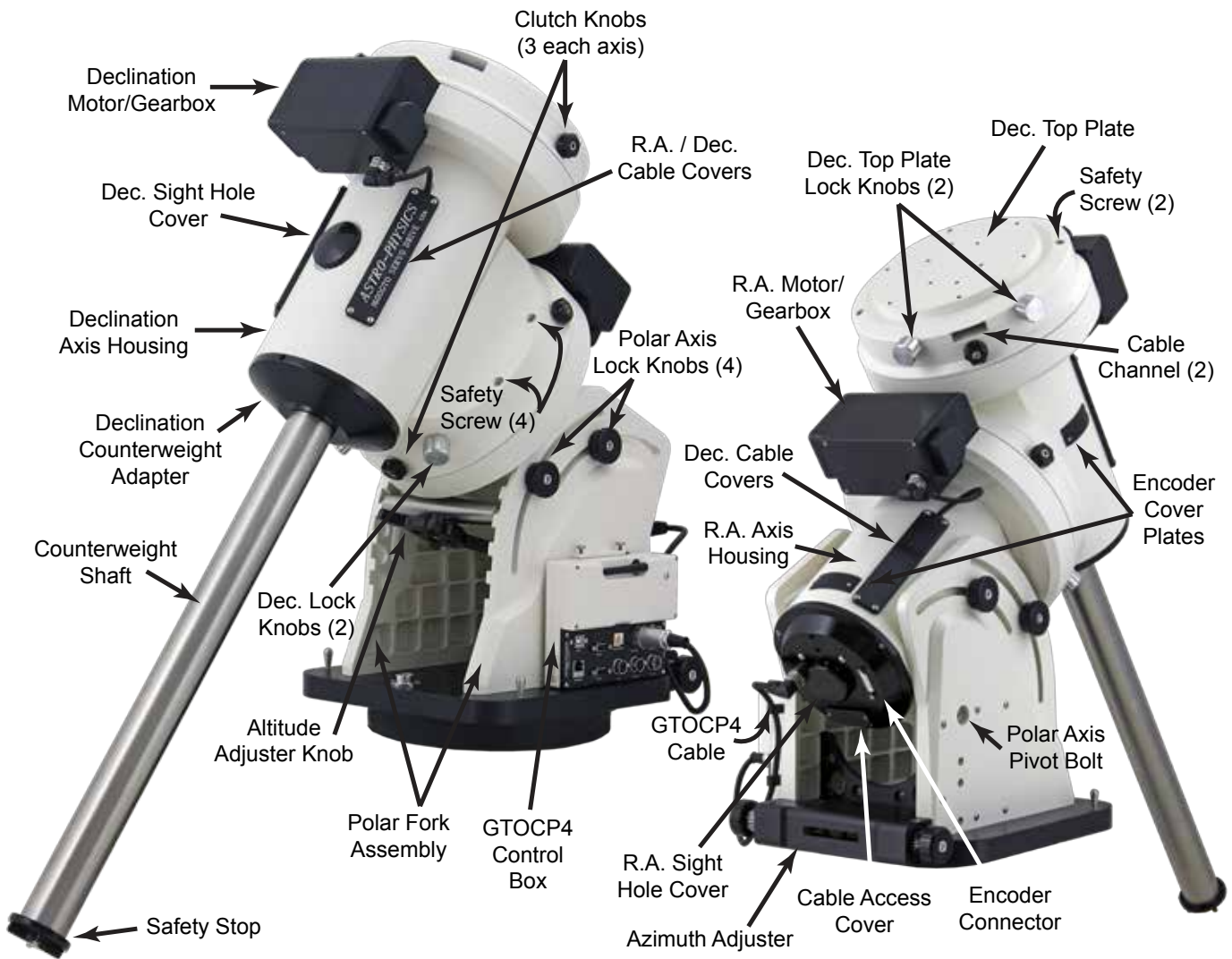

# NOW IT'S TIME TO SET UP!

## ***Additional Handy Tools***

### ***In Your Accessory or Tool Box:***

- Small torpedo level - Use to level your scope when using the handy reference park positions, particularly during the daytime polar alignment routine outlined in the Keypad manual.
- Compass - You must know your magnetic offset when using a compass (there can be a large difference depending on your location).
- Documentation - Physical copies of your mount, control box and keypad (if you have one) manuals as well as any other documentation that you received with your mount (or control box) or that you find in the Support section of our website that may be useful. Alternatively, you can simply save the PDFs to your computer if you are using one.
- Hardware and Tools - The prepared astronomer always carries extra screws and fasteners when traveling away from home. A set of tools (screwdrivers, hex keys, pliers, strap wrench, etc) and cables (power and communication) may also save a dark-sky trip if a problem occurs.

### ***On Your Smart Phone:***

For the upmost of convenience, the following items can be downloaded to your smart phone, which you are likely to carry with you everywhere.

- App(s) that allow your phone to be used as a level, inclinometer and compass. Remember, you must know your magnetic offset when using a compass since there can be a large difference depending on your location.
- Astro-Physics Polar Alignment app – The longitude and latitude of your current site will display. Apps are available for iOS, Android and Windows and is also included as part of the AP V2 ASCOM driver.
- Download PDFs of all relevant and recent documents from the Support section of our website or you can link to our website if you have service at your observing site.

# AT YOUR OBSERVING SITE

## Assemble Pier (purchased separately)

Begin by assembling the portable pier at the desired observing location. Take note which direction is north. (These instructions are for the Astro-Physics Portable Piers. For other piers, please follow the manufacturer's instructions.)

1. Slide the three legs onto the nubs of the base and rotate the assembly so that one of the legs points toward north (or toward the south if in the southern hemisphere).
2. Place the pier post on the base, orienting the eyelets for attaching the turnbuckles directly above each leg.
3. Attach the tension rods. The turnbuckles should be drawn tight until the whole assembly is stiff enough to support your weight without movement.

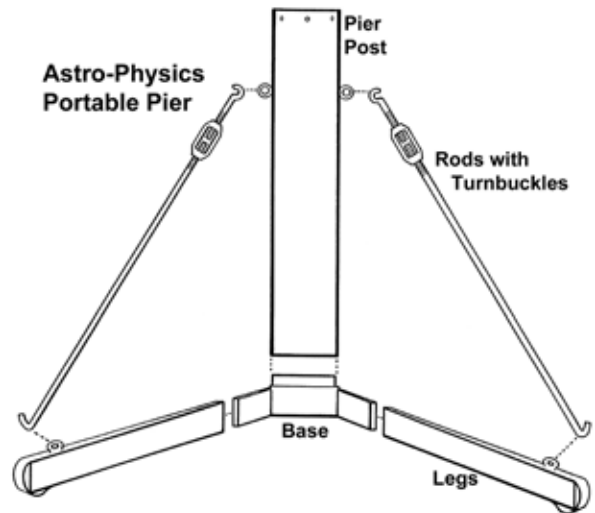

## Attach Polar Axis Assembly to Pier

In order to track the motion of astronomical objects, the Polar Axis must be positioned so that an imaginary line drawn through the center of the axis points toward the celestial pole. Refer to the diagram at the front of this manual for a graphical representation. At this stage of the assembly process, you want to position the pier so that it points roughly north.

1. **Prior to mounting the Polar Axis.** Adjust the Azimuth Adjuster so that the Azimuth Adjuster Block is centered. This will allow for greater adjustments when it comes time to polar align the mount.
2. **Orient the pier.** Set up your pier so that the counterweight shaft is oriented above the north pier leg. It is important when using a portable pier to face one leg to the north so that the offset weight of the counterweight shaft and counterweights do not create an unstable balance.

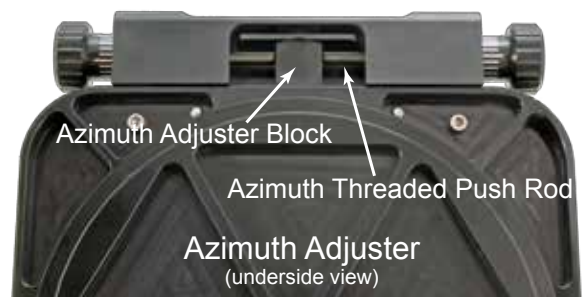

3. **Set the R.A. Axis in place.** Carefully set the 1600GTO Right Ascension Axis / Polar Fork assembly into the open top of your pier, or into the 1600 Flat Surface Adapter (1612FSA), if you are using one. Unless you are quite strong, it is ideal to have two people involved in the operation of lifting and stabilizing the assembly as it is positioned into the pier or 1612FSA.
4. **Line up the Pier base.** If the side thru-holes in the pier or 1612FSA are not perfectly lined up with the tapped holes in the mount's Pier Adapter base, rotate the mount, noting that the azimuth adjuster knobs should be locked to the adjuster block. Otherwise, the base will rotate making it difficult to line up the holes.
5. **Secure the R.A. Axis to the pier.** When you have the holes lined up, fasten the mount to the pier top or to the Flat Surface Adapter using six 5/16-18 X 5/8" socket button head cap screws and 5/16 flat washers. Note that the washers have a sharp edged side and a softly rounded side. Be sure that the rounded side faces the paint or anodizing of the pier so that no marring of the finish occurs. Be sure to start all six cap screws (with their washers) before tightening any of them. Then, snug all six cap screws down before finally tightening them all securely.
6. **Level the mount.** Although it is not important that a German equatorial mount be level to achieve polar alignment, it does make it easier since an adjustment to altitude or azimuth affects only the direction to which you are making the adjustment. If the mount is not level, you will be able to achieve alignment, but when you make an adjustment to azimuth, for example, you are actually making an adjustment to both directions when out of level. Note that if you are using the Right-Angle Polar Scope, it is required to be level in the east-west direction in order to achieve accurate polar alignment. Level the mount...you'll be ahead in the game!

**Special note: It is a very good idea to include a small torpedo level and a compass in your accessory carry box, along with your other tools, when setting up portably. Modern cell phones, such as the iPhone, have Apps available that allow the phone to be used as a level, an inclinometer and a compass.**

## Latitude Adjustment for 1600GTO German Equatorial Mounts

The 1600 mount accommodates a latitude range from 0 to 78 degrees and 90 degrees. The Altitude Adjuster Bar allows for gross latitude ranges, while the Adjustment Knob is used to provide the precision adjustments when polar aligning. The Altitude Adjuster Bar is positioned into one of nine slots which provide an overlapping latitude range.

This altitude bar is very convenient when travelling to remote sites, as it allows you to transport your mount in the more compact, zero-latitude position. You can change to your remote site's latitude in one quick motion of the altitude bar.

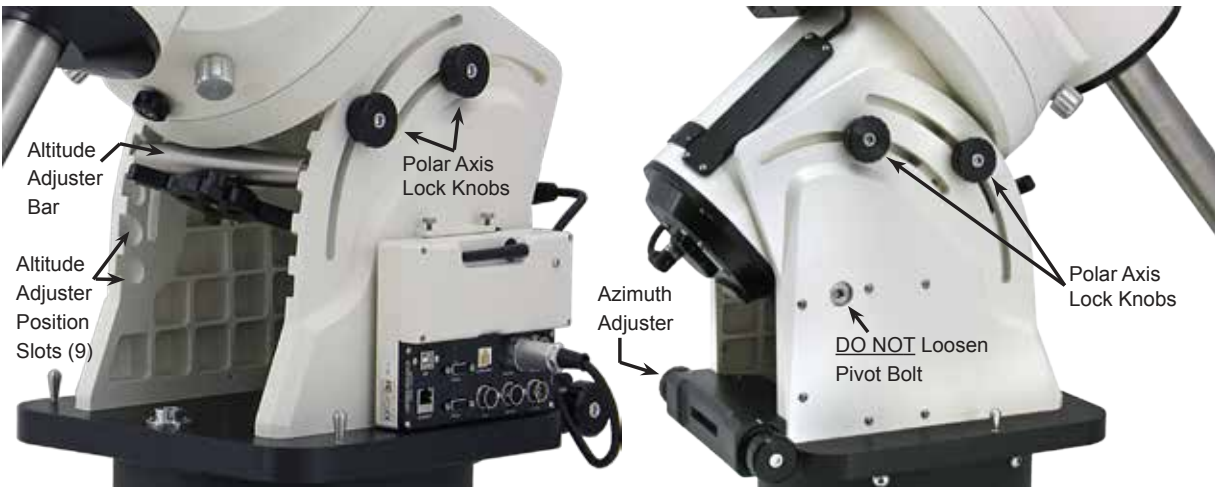

### How to change the position of the Altitude Adjuster Bar

1. Use only the R.A. axis. DO NOT attempt to make these adjustments with the declination axis in place and certainly not with an instrument fully mounted.
2. Loosen all four Altitude Lock Knobs about 1 turn.
3. The mount's Polar Axis is held in place between the two side plates of the Polar Fork. The axis pivots on custom shoulder bolts located towards the rear of each side plate. These bolts should not be loosened when making altitude changes to the mount.
4. Tilt the R.A. axis upwards and hand tighten the lock knobs so that the axis does not drop while you are repositioning the Altitude Adjuster Bar.
5. Note that the Altitude Adjuster Knob is attached to a threaded rod that travels through the Altitude Adjuster Bar. Turn the knob so that you see about half of the threaded rod protruding from both sides of the Altitude Adjuster Bar. This will allow you to move the mount fully within the altitude range. The slots are positioned at 9 degree increments and the threaded rod has 10 degrees of travel. They represent the following altitudes:
  - a) Slot 1 - 0-10° center: 5°
  - b) Slot 2 - 10-20° center: 15°
  - c) Slot 3 - 19-29° center: 24°
  - d) Slot 4 - 28-38° center: 33°
  - e) Slot 5 - 37-47° center: 42°
  - f) Slot 6 - 46-56° center: 51°
  - g) Slot 7 - 55-65° center: 60°
  - h) Slot 8 - 64-74° center: 69°
  - i) Slot 9 - 73-78° Note - it is necessary to remove the Lock Knobs and shift the mount into its 90° position in order to utilize this upper slot. Once done, lower the axis and restore the knobs.
6. Shift the Altitude Adjuster Bar into the correct slotted position. Note that the re-positioning is done so quickly and easily that trial and error positioning is inconsequential. There is a degree scale on each Polar Fork with a corresponding indicator line on the back of the worm wheel housing to assist you. (See photo following page)

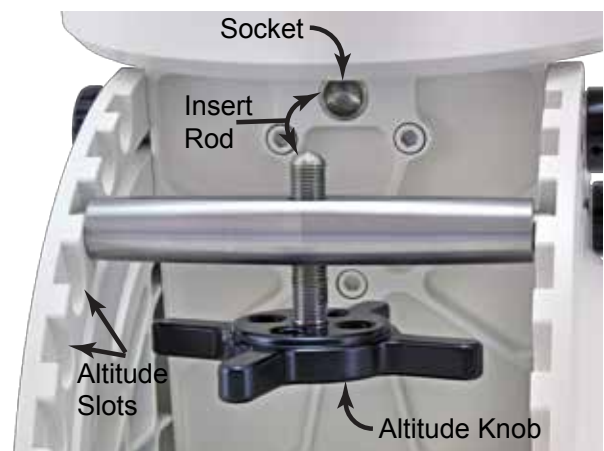

- Note that the threaded rod has a rounded end. Also observe that the underside of the R.A. axis has an inset socket. When you loosen the Altitude Lock Knobs and lower the polar axis be sure that the rod comes to rest fully seated in this socket. A little wiggle of the adjuster knob will ensure its proper seating.
- Turn the Altitude Adjustment Knob to raise or lower the Polar Axis to your approximate observing latitude (note the previously mentioned altitude lines on the side). Tighten the altitude locking knobs with finger pressure only. You do not need to tighten with the hex key.
- Later, as you adjust the mount's altitude when polar aligning, you should always make the final adjustments pushing upwards. Additionally, the locking knobs should be increasingly tightened as the final adjustments are made.



**Recommendation:** Rough polar positioning of the mount and pier should be done with the R.A. axis only since you will be making major adjustments to level the mount, aim it north and set the elevation. The remainder of the mount, telescope and counterweights will add considerable weight and require more effort when positioning. Later, you will do your actual polar alignment with telescope and counterweights attached, but the adjustments will be comparatively small and within the range of the altitude and azimuth fine adjustments. An inclinometer and a compass adjusted for magnetic declination at your location (or these functions on a smart phone App) are recommended.

## Special 90 Degree Alt-Azimuth Position

One of the unique design features of the 1600GTO mount is its ability to be placed into a 90° Alt-Azimuth position. This allows specialized functionality for research applications, as well as terrestrial viewing. In order to achieve maximum stability, it is important to maintain the center of gravity directly above the pier. This requires that the R.A. axis be reversed in the polar forks. The change over is outlined below in illustrations and description. **Note: This axis reversal must be done by two people...one to hold and reverse the axis and the other to remove and replace the bolts.**

- Remove telescopes and counterweights before beginning this orientation change. It is also necessary to separate the Dec. axis so that you are only working with the R.A. axis and forks.
- Remove all four Altitude Lock Knobs.
- Tilt the axis upward to its maximum balanced position and remove the Altitude Adjuster Bar and set aside. The axis must be held in place as there is no way to secure it.
- While one person holds the R.A. axis, have the other person remove the two shoulder bolts that are the Pivot Bolts for the axis. Remember that the full weight of the axis will need to be supported.
- Lift the axis straight up and out of the polar forks. Walk around to the other side of the mount so that the R.A. axis can then be lowered back into place, but now facing the other way.
- Align the Pivot Bolts with their respective threaded holes and screw into place. Do not tighten them until both bolts have been fully threaded and the axis rotated slightly back and forth to ensure that it is properly seated. Now tighten the bolts fully.
- Replace the four Altitude Lock Knobs. Notice that they will all be in the lower channel. Two of the knobs are placed into the available threaded holes that were previously unused. Use a bubble level to position the axis and secure the knobs tightly using a 1/4" hex key. You now have an Alt-Azimuth mount.

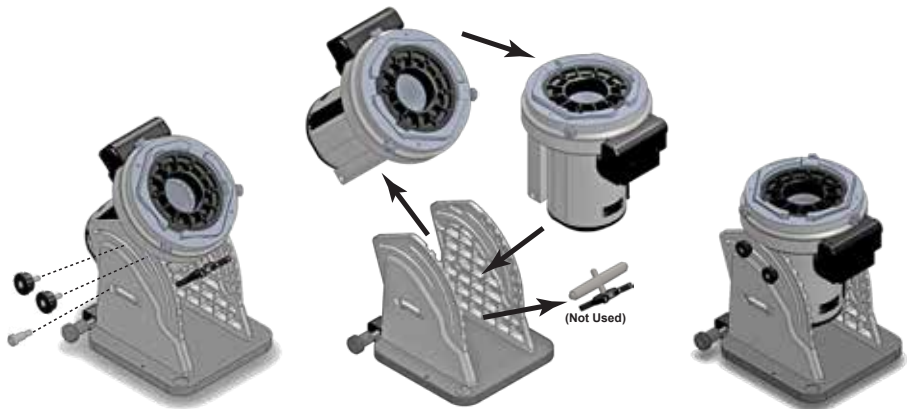

**Important Note:** We do not offer software for the 1600GTO mount configured in the Alt-azimuth mode at this time. It will be necessary for you to write your own command protocol. However, it can be used manually via button moves.

# ASSEMBLY INSTRUCTIONS

## Assembly of R.A. and Dec. Axes

One of the many features of the 1600GTO mount is internal wiring, which offers protection and convenience. It eliminates many of the concerns, such as cable-snags and excess dew exposure to electrical parts, when the telescope is in use both in the backyard and at remote sites.

Much of the wiring is factory installed and not of concern to the user. However, the exception is the Dec. servo motor connection. It is necessary to attach the Dec. Servo Cable to its connector when joining the Dec. and R.A. axes. It is equally important to remember to detach the connection when separating the mounts two axes. Otherwise, damage could occur to the internal socket / circuit board or the Dec. axis could be pulled from your hands as you start to walk away.

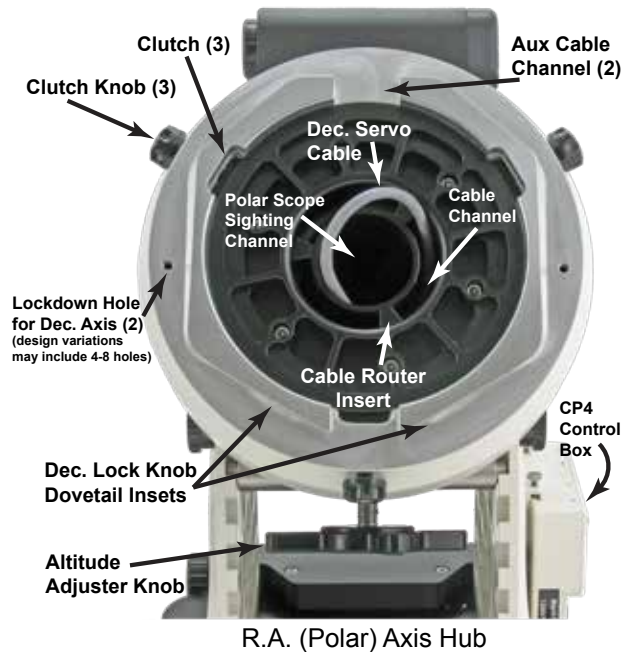

## Assembly Procedure

This section assumes that you are only running the motor cables through the mount. If you plan to run more cables, please read the next section entitled “Cable Management” before proceeding.

1. Ensure that the R.A. (polar) axis is securely attached to its pier before proceeding.
2. Notice that the Dec. Servo Cable routes through the R.A. axis. There is also a removable Cable Router Insert (seen at right) provided with the mount which serves the purpose of keeping any internal cables out of the light path of the polar scope. If you will not be using a polar scope, then you have the option of not using the cable router. When assembling the mount, position the Dec. Servo Cable along the side of the insert and loop it back into the center of the insert. This will keep the cable out of the way when attaching the Dec. axis to the R.A. axis.
3. Rotate the R.A. axis to the position shown in the illustration with the two clutches at the top and the single clutch at the bottom. Note that the auxiliary cable channels line up vertically and that the Dec. locking knob dovetail insets are at the bottom.



4. During shipment, the Dec. axis lock knobs will be fully screwed into the Dec. axis. You will need to back these out (approximately 8+ turns) until the tip is fully retracted (the knob is removed with approximately 21 turns).
5. Position the Dec. axis above the R.A. axis (as illustrated with the image to the left). Then hook the top of the dovetails of the two axes together and tilt the axis into place while giving a light wiggle so as to properly seat them (shown by arrow “A”).
6. When the Dec. axis is fully seated, hand tighten the two locking knobs fully.
7. There are four 1/4” counter-bored holes (two on each side) on the front of the Dec. axis. Insert a 1/4-20 x 3/4” socket head cap screw into each of the holes and tighten. **It is important that you tighten the locking knobs fully before adding these screws, so that the dovetail of the Dec. axis is properly seated.** These provide additional security and rigidity for the heavier capacity of the mount.
8. Remove the Dec. Counterweight Adapter by unscrewing it. If it is too tight to turn by hand, you may insert a hex key into one of the two holes at the side of the adapter in order to gain leverage.
9. Reach inside the axis and retrieve the Dec. Servo Cable that

was inserted into the center of the R.A. axis Cable Router. Connect the cable to the connector box as shown in the illustration and tighten the retaining ring. Attach the encoder cable, if you have one.

10. Replace the Dec. Counterweight Adapter.
11. Thread the counterweight shaft into the Dec. axis. Ensure that the plastic washer is in place on the threads of the shaft so that the shaft will be easier to remove later.
12. Attach the Dec. Top Plate to the axis and lock it in place by hand tightening the two lock knobs. You may wish to insert and tighten the two 1/4-20 x 5/8" socket head screws that provide additional attachment security. ***It is important that you tighten the lock knobs fully before adding these screws, so that the dovetail of the Dec. Top Plate is properly seated.***



## Disassembly Procedure

1. Essentially, one reverses the assembly procedure. Start by removing the telescope, counterweights and counterweight shaft.
2. Remove the Dec. Counterweight Adapter by unscrewing it. If it is too tight to turn by hand, you may insert a hex key into one of the two holes at the side of the cap in order to gain leverage.
3. Reach inside the axis and disconnect the Dec. Servo Cable at the connector box as shown in the illustration (see above illustration). Tuck it back into the center of the R.A. axis for safety and to prevent damage.

**DO NOT FORGET to disconnect this cable before separating the axes!!!**

4. Replace the Dec. Counterweight Adapter.
5. Remove the 1/4-20 security screws from the lock-down holes (if they were used) and loosen the two Dec. axis locking knobs 8+ turns.
6. Separate the two axes as shown by letter "B" in the previous assembly illustration.
7. For transport and storage, we recommend re-tightening the Dec. locking knobs.
8. Place the R.A. axis in the zero-degree altitude position for compact transport.





# CABLE MANAGEMENT

It has become more important than ever to find ways to manage cable routing. We now have the lure of imaging and with it the addition of accessories requiring power and computer connectivity. In addition to multiple dew heater cables, we have CCD cameras, color filter wheels, camera rotators, motorized focusers, autoguiders, adaptive optics units and the list goes on... All these devices have power cables and USB or serial cables that need to be managed. To simply allow all these cables to dangle would make your telescope look as though it is having a very "bad hair day" and it would invite disaster. At the very least, dangling cables create flexure that results in bad star shapes in your images; at worst, they cause cable snags and damage to your equipment.

The 1600GTO allows you to pass all your cables through the mount while maintaining a visual path for a polar scope. It is the most advanced cable management system on the market today. We have gone to great lengths to design and engineer the 1600GTO mount to incorporate this feature. This task was made more complicated by our philosophy that our mounts should be portable and the two axes need to be able to be separated for the ease of setup and transport by our customers. Since our mounts can be portable, we further added to our challenge by requiring the ability to use a polar alignment scope for speeding set up time and alignment accuracy. We have accomplished these goals.

**CAUTION! After you run cables through your mount, you must keep in mind that they are there. To avoid problems from twisting, DO NOT EVER rotate the mount a full revolution or more (> 360°) while cables are inside. You can damage the cables. Operations where this might occur are balancing, re-greasing and other maintenance activities. GTOCP4 software versions VCP4-P01-11 and later will not allow the servo to rotate the axes beyond this limit. If you rotate the mount, do not forget to de-rotate it before continuing your activities.**

## Preparation

**Think ahead!** The key to good cable routing is good planning. Every imaging setup is somewhat unique. The equipment is different and the selection of devices depends upon the type of imaging that interests you and the level to which you wish to take it. As systems become larger and more complicated, the greater the importance of planning and organizing. It is not as simple to add a cable later when it becomes necessary to remove a large and heavy systems in order to do so.

It is best to lay out your imaging system and connect all the wiring so that you have a good idea which cables need to be routed through the mount. This can be done by spreading your devices on a table; they do not actually need to be set up on a telescope. This will also allow you to have an idea about cable length, if there are choices to be made. Once you have all your devices connected and know that you are not forgetting an important power cable or other critical necessity, you are set to begin the actual process of routing your cables.

You may wish to consider reducing the number of cables needed by running a single power cable up through the mount to a power distribution hub, such as a RIGRunner, on top of your instrument package. Similarly, you can run a single communication cable through the mount to a communication hub, such as an ICRON Ranger, located at the top. Using these hubs can simplify and improve the quality of your setup.

## The Basics

The 1600GTO mount has some very unique features that assist you with your cable management. Starting at the top of the mount, notice that there is a removable Dec. Top Plate. This plate allows you to attach various dovetail saddles and specialty plates for the many, varied telescope systems to be found today. It is also removable via a unique and powerful dovetail system so that you have unobstructed access to the internal central routing core of the mount. The bottom of the Dec. axis also has a removable Counterweight Shaft Adapter that unscrews to allow access internally so that routing cables can be done more easily.

The R.A. axis has a clever Cable Router Insert which is removable. This insert serves the dual purpose of organizing the routing of cables while preserving a clear light path for the polar scope. In a permanent observatory setup, it is not necessary to use the insert, though it may certainly be left in place, as it will not restrict the number of cables that can be run. It is designed to be removable so that cables can more easily be routed through the mount and then replaced to secure the light path.

The final part of the internal cable routing system is the Cable Access at the bottom of the rear R.A. Plate. This access has a cover that is removable by undoing the two socket head cap screws securing it. Once removed, cables with connectors as large as RS-232 cables can be fed through the opening. It is always a good idea to feed the largest connectors through first before moving on to the smaller sizes. If you do not plan to use a polar scope, you have the additional option of routing the cables through the central opening.

## The Specifics

What follows are some more detailed instructions for installing your cable package into the 1600GTO. You will, of course, have to tailor the instructions for your own particular needs. These instructions are for the routing of auxiliary cables for

cameras, dew heaters, focusers and other devices that are not a component of the 1600GTO. The mount's own cables are discussed earlier in this manual in the sections on mounting the declination axis. Use the Assembly Diagram found earlier in the manual to help identify the named parts below.

There are two options for running cables through the 1600GTO. If you have the mount set up permanently in an observatory and have no plans for the use of a polar scope, you can choose to not use the cable router insert and can run your cables through the mount while the two axes are joined. This has the advantage of more easily adding a cable later by fishing it through the mount while assembled. If you will be using a polar scope for setting up portably or if you plan its use at any time while set up permanently, then you will need to run your cables through the R.A axis first.

We shall first discuss the procedure for routing cables with the anticipation of using a polar scope. This option hinges on the need for placing the wires through the R.A. axis and then placing the cable router insert. It is only possible to run cables with small connectors after the cable router is in place and it may present difficulties once the mount has been fully assembled and equipment in place. As one sees in the illustration of the R.A. Axis Hub, the Cable Router creates three narrow cable paths around the outside of the light path. However, the Cable Router Insert is easily removed and replaced in order to change existing cables or if you choose to add additional ones while the Dec. axis is detached.

### Routing Cables if You Plan to Use the Cable Router Insert When Using the Polar Scope

1. Start with the R.A. (polar) axis properly installed on your pier.
2. Remove the Cable Router Insert and set to the side for later use.
3. Remove the Cable Access Cover from the rear plate of the R.A. axis by unscrewing the two socket head cap screws. Store it in a safe place, as it will not be used while cables are routed through the mount.



Note: you may find it helpful to also remove the Polar Scope Adapter Cap in order to have more light and to better see what you're doing. Just remember not to accidentally run a cable through the polar scope opening (assuming that you plan to use the polar scope)!

4. Begin by feeding the cable with the largest connector from the front of the axis to the rear. You will need to finesse the cable through the rear Cable Access opening. If you are having trouble coaxing the connector through the opening, you can always use the electrician's trick of first snaking a length of cord or thick string through the cable channel by attaching it to the end of a straight wire or similar probe of sufficient length to pass through the axis. Continue feeding your cables through the cable channel. Note that if you have a number of cables to run, then it may be best to use the electricians trick and pull them all through at one time.
5. Insert the Cable Router into place while making sure that the installed cables are positioned in the channels. If you have a number of cables installed, then you may wish to divide them between the three channels, or separate power and communication cables.
6. Since you must still attach the Dec. Axis, you do not want to have the full length of the cables running through the R.A. axis, as the ends of the cables must be looped back into the center of the Cable Router as described in an earlier section referencing the Dec. motor / communication cable. Loop the ends of the cables into the center of the Cable Router. This is done in preparation of joining the Dec. and R.A. axes.
7. Attach the Dec. axis as described earlier and lock into place with the Lock Knobs. Insert and tighten the two socket head screws that provide attachment security. Remove the Dec. Counterweight Adapter.

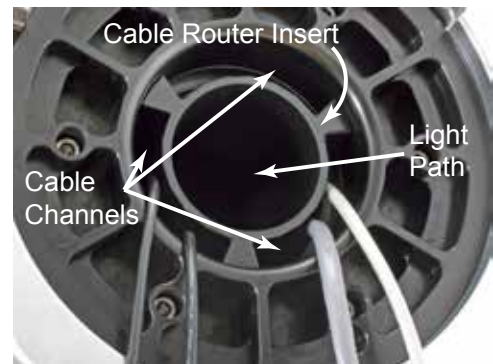

8. At this point, unloop and route the Dec. power / communications cable as described in the R.A. / Dec. Assembly section. Attach it to its Dec. socket. Replace the Dec. Counterweight Adapter.
9. Next unloop and route the remaining cables up through the center of the Dec. axis. Cable lengths can be adjusted at this point.

Note: It may be advisable to make a tool for snagging the wires and pulling them up through the Dec. axis. This can be done by bending a wire clothes hanger (or similar) into a hook shape. Be sure to take care not to damage any of the interior wiring in the mount.

10. Decide which direction the cables should go (most will likely be towards the back of the scope, while some may best be towards the front) and direct them accordingly through either of the two cable channels found on the Dec. Axis Hub. This is a good time to further adjust the cable lengths as needed.

11. Attach the Dec. Top Plate to the axis and lock it in place by hand tightening the two lock knobs. You may wish to place and tighten the two 1/4-20 x 3/4" socket head screws that provide additional attachment security. ***It is important that you tighten the lock knobs fully before adding these screws, so that the dovetail of the Dec. Top Plate is properly seated.***

## Routing Cables if You Don't Plan to Use the Cable Router Insert

1. Start with the R.A (polar) axis properly installed on your pier.
2. Remove the Cable Router Insert, if it was installed.
3. Attach the Dec. axis as described earlier and lock into place with the Lock Knobs. You will also want to place and tighten the two socket head screws that provide attachment security. Remove the Dec. Counterweight Adapter and connect the Dec. power / communications cable as previously described.
4. Remove the Cable Access Cover from the rear plate of the R.A. axis by unscrewing the two socket head cap screws. Store it in a safe place, as it will not be used while cables are routed through the mount.

Note: It may be advisable to make a tool for snagging the wires and pulling them up through the Dec. axis. This can be done by bending a wire clothes hanger (or similar) into a hook shape. Be sure to take care not to damage any of the interior wiring in the mount.

5. Begin by first feeding the cable with the largest connector through the Cable Access opening at the bottom rear of the R.A axis. You will need to finesse the cable through the opening and up through the center of the axis. If you are having trouble coaxing the connector through the axis, you can use the electrician's trick of first snaking a length of cord or thick string through the cable channel by attaching it to the end of a straight wire or similar probe of sufficient length to pass through the axis. Continue feeding your cables through the cable channel. Note that if you have a number of cables to run, then it may be best to use the electrician's trick and pull them all through at one time.
6. Now is the time to utilize the "snagging tool" that you created. It can be used to reach the cables as they peek out of the R.A. axis opening and you can then pull them up through the Dec. center. Alternatively, the electrician's trick of using a cord or thick string to pull the cables through the interior of the mount is a good one.

Note: This may be a good time to recommend routing a cord or thick string through the mount while routing the cables. It is convenient to have this option available to you should you ever wish to add a cable for a new device at a later date. It can simply be left in place until needed.

7. Decide which direction the cables should go (most will likely be towards the back of the scope, while some may best be towards the front) and direct them accordingly through either of the two cable channels found on the Dec. Axis Hub. This is a good time to further adjust the cable lengths as needed.
8. Attach the Dec. Top Plate to the axis and lock it in place by hand tightening the two lock knobs. You may wish to place and tighten the two 1/4-20 x 3/4" socket head screws that provide additional attachment security. ***It is important that you tighten the lock knobs fully before adding these screws, so that the dovetail of the Dec. Top Plate is properly seated.***



Dec. Top Plate Removed



Dec. Top Plate in Place

# ATTACH MOUNTING PLATE

*(purchased separately)*

Take note of the hole-patterns available on the Declination Top plate of the 1600GTO. Most of you will use either the outer six-hole bolt pattern or else the inner four-hole bolt pattern to attach your mounting plate. Some of the plates can use bolt holes from both the four and six hole-patterns. Please note that the mounting plates below are drawn at a smaller scale than the hub at right. The plates are relatively at scale with each other for comparison.

Several mounting plates (also called cradle or saddle plates) are available for the 1600 mount. If you own more than one instrument, you may need more than one plate. Follow the appropriate directions for the plate(s) that you have. The darkened holes represent those used for the 1600 mount.

**1600GTO Dec. Top Plate Mounting Hole Pattern**

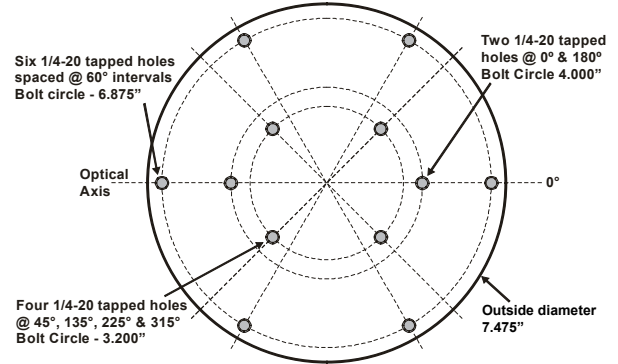

Discontinued plates are shown for the long-time customers who may already own one.

## Fixed Mounting Plate Options

### 18" Flat Mounting Plate (FP1800) (Discontinued)

This plate is 18" long and 7.5" at its widest point in the center. The width of the plate tapers to 5.5" at each end. Four pairs of keyhole slots that measure 3.2" between centers are provided. The two inner pairs are 13.75" apart and the outer two pairs are 17" apart. You can drill additional holes to suit your needs. This plate also fits the 900, 1100 and 1200 mounts. Attach this plate with six 1/4-20 x 1" flat head socket cap screws.



### 15" Ribbed Mounting Plate (1200RP15)

This plate is 14.75" long, 7.75" at its widest point, 5" at each end and 1" thick. The underside of the plate is carved into a ribbed pattern to maximize the strength and minimize the weight - 3 lb. A pair of keyhole slots that measure 3.2" between centers are provided at each end. The distance between the pairs is 13.75".

Attach this plate with six 1/4-20 x 3/4" socket head cap screws. Note that the plate is asymmetrical. In most cases, orient the plate so that the long end points toward the sky. You can also turn the plate in the other direction to balance your scope.



### 24" Ribbed Mounting Plate (1200RP) (Discontinued)

For larger instruments, the ribbed structure of this plate provides the maximum support. Our machinist begins with thick aluminum plate and carves a strong rib structure. The final result is 1.5" thick, 24" long and 7.6" at its widest point. The width of the plate tapers to 5.5" at each end. A pair of keyhole slots that measure 3.2" between centers are provided at each end. The distance between these pairs of holes is 23". Due to the ribbed structure, you may not be able to drill additional holes for non Astro-Physics mounting rings. The plate weighs an amazing 9.5 lb. for its size. This is a view of the rib structure on the underside of the 24" plate.

Attach this plate with six 1/4-20 x 1" socket head cap screws.



## Losmandy D-Style Compatible Saddle Plate

### **16" Easy-Balance Dovetail Saddle Plate for Mach1GTO, 900, 1200 and 1600 Mounts and Losmandy D-Style Plates (DOVELM162)**

This Astro-Physics plate was introduced in February, 2009, and in mid-2010 we added the center clamp for even greater versatility. The DOVELM162 provides a multitude of mount attachment options, and was specifically designed to meet the balancing demands of "back-end-heavy" instruments like SCTs and Ritchey-Chrétiens, especially those with heavy imaging gear hanging off the back!



This plate has small knobs to avoid interference with the declination hub, but the knobs have cap screws in the ends that accept a 3/16 hex wrench for extremely secure clamping of your instrument. Additional features include ribbed structure underneath to reduce weight and tapped 10-32 holes in the side for cable attachment. This is the perfect saddle for our SBD16 16" Versatile Dovetail Plate!

Note that the bolt-hole patterns are marked with scribe cuts. The four-hole patterns can all be supplemented with bolts along the optical axis in the six-hole pattern giving six attachment points at each position. Attach this plate with four 1/4-20 x 1" socket head cap screws and possibly one or two 1/4-20 x 3/4" flat head socket cap screws.

## Side-by-Side D-Style Option

### **13" and 16" Side-by-Side D-Series Plates (SBD13SS & SBD16SS)**

These plates will fit into any of the three D-series compatible plates listed above and will accept either the DOVELM2 or the DOVELM162 as the instrument saddle plates for each scope. The 13" plate allows optical axes to be placed on 9.5" (250 mm) centers, and the 16" plate allows instruments on 12.5" (318 mm) optical centers.



## ***Astro-Physics P-Style Compatible Saddle Plate***

### ***16.5" Dovetail Saddle Plate for PlaneWave Dovetail Plates (DOVEPW)***



This robust plate allows attachment of instruments like the PlaneWave CDK17 or CDK20 that use their 7.652" wide dovetail plate. The plate was originally designed for the 3600GTO mount, but it works extremely well on the 1600GTO with the PlaneWave CDK17 and CDK20. We do not recommend their larger scopes for the 1600GTO. Four clamps secure the instrument like a vise! Note that the attachment screw placement requires that the plate be rotated 90 degrees from the conventional orientation in order to accommodate the two center clamps. You can achieve an added measure of security when using our 23" P-Style Dovetail Plate (SBPW23). A series of matching 1/4-20 holes in each plate enable you to bolt them together once the balance position of your instruments is achieved. Attach with six 1/4-20 x 1" socket head cap screws.

## ***Side-by-Side P-Style Option***

### ***Side-by-Side with P-Series Plate (SBPW23)***

A variety of P-style side-by-side configurations are possible using the 23" Dovetail Plate (SBPW23). One example is shown in the photo to the right where a P-style Dovetail Saddle (DOVEPW) is attached on the right and a 16" Losmandy D-style Dovetail Saddle (DOVELM162) is attached on the left. It is also possible to set up a side-by-side configuration using two, or even three, DOVELM162 saddles attached to the SBPW23. When assembling a multi-scope system you have to be mindful of the total combined weight of the components and accessories (remember that a simpler system is always better). An additional DOVEPW will be used to attach the SBPW23 to the mount.



# ATTACH COUNTERWEIGHT SHAFT AND COUNTERWEIGHTS

## IMPORTANT:

- Always attach the counterweights before mounting the telescope to the saddle plate to prevent sudden movement of an unbalanced tube assembly, which may cause damage or injury.
  - Remember counterweights are heavy and will hurt if they fall on your foot.
1. Thread the Counterweight Shaft onto the Dec. axis. Be careful not to cross-thread! Do not tighten too much, since you will need to remove it. Also be sure that the Delrin washer is in place on the threads to facilitate the shaft's removal later.
  2. Remove the machined Safety Stop from the end of the Counterweight Shaft. Add sufficient counterweights (5, 10, 18, or 30 lb. counterweights are available) to the shaft to balance the telescope you intend to use. Loosen the counterweight knob and hold the counterweight with the knob pointing downward so that the brass pin will move from the center opening allowing the counterweight to slide into position. Always use two hands to attach or move them on the shaft. It is advisable to position the counterweight knob pointing down toward the pier. This will minimize the chance of accidentally loosening the counterweight during the observing session.
  3. Re-attach the Safety Stop to the end of the Counterweight Shaft. This will help to prevent injury if someone accidentally loosens the counterweight knob.

NOTE: A firm tightening of the counterweight knob will not damage the surface of the Counterweight Shaft. The pin that tightens against the stainless Counterweight Shaft is constructed of brass.

# ATTACH MOUNTING RINGS AND SCOPE

*(purchased separately)*

**If this is your first session with your new mount, you may wish to read the “Understanding R.A. and Dec. Clutch Knobs” section before attaching your telescope. This will give you an idea of how the clutch knobs feel and function.**

**Flat and ribbed plates:** Our flat and ribbed plates are constructed with keyhole slots at the location where your mounting rings attach. This feature enables you to partially loosen the screws on your rings just enough to insert them into the larger part of the keyhole, then slide the rings to the narrow part and tighten them with a hex key. We prefer this keyhole method to the standard way of completely removing the screws and dropping them in the grass.

We suggest that you install the rings on the mounting plate, then open the rings, lift the scope in place, close the rings and tightened the knobs. To balance the scope, you can loosen the knobs enough to slide the scope forward or backward as needed.

Another approach is to attach the rings to the scope beforehand, then lift onto the mounting plate. However, the rings must be spaced exactly the correct distance apart to match the holes in the plate. This maneuver may be particularly difficult to accomplish with a large, heavy instrument.

**Dovetail plates or sliding bars:** Attach mounting rings to the male dovetail plate (sliding bar) matching the appropriate threaded holes on the bottom of the mounting ring. Again, you have the option of attaching this dovetail / ring assembly to the mount and then lifting your scope in or placing the scope in the rings, then lifting the entire assembly to the female mounting plate already attached to the mount. Dovetail plate / sliding bar combinations are quick, versatile and convenient – hence their popularity. Simply loosen the knobs and “tilt” the sliding bar into place in the dovetail receiver. Once in place, tighten the knobs to lock everything securely. Loosen the knobs and slide the scope / rings / sliding bar assembly in the dovetail channel as needed to balance the system, and then re-tighten when balanced.

**Side-by-side:** Users may wish to mount dual scopes for viewing or imaging reasons. All that needs to be done with our mounts (except the Mach2) is to rotate the Dec axis so that the saddle plate aligns east-west.

Once this is done, the side-by-side dovetail plate (SBD13SS or SBD18SS) can be inserted and an additional dovetail saddle attached to each end of the plate. These end saddles will be pointing to the north celestial pole. Note that a total of three saddles will be used.

When the mount is powered up, initialize it from a reference park position. See section on balancing a side-by-side system.

# UNDERSTANDING THE R.A. AND DEC. CLUTCH KNOBS

**WARNING!** *Be careful when moving the mount with the clutches. It is possible to catch cables or fingers between the clutch knobs and the motor/gearboxes if you are not careful!*

**CAUTION!** *When moving the mount via the clutches, the servo is not involved, and therefore is not keeping track of the axis' positions. Bear in mind that internally run cables can be twisted and damaged if you are not keeping track of, and accounting for movements made using the clutches. If cables are run internally, you do not ever want to rotate an axis more than 360°. If you rotate the mount, do not forget to de-rotate it before continuing your activities.*

1. What do they do?

The three R.A. and three Dec. Clutch Knobs depicted in the Assembly Diagram have the function of connecting the R.A. and Dec. Axes to their respective drive worm wheel gears. Their function is progressive, from slight tension (axes free to move - as required during correct balancing of the telescope) to a completely "locked up" state.

2. How can you find out what they really do?

As shipped, all 1600 mounts have both sets of R.A. and Dec. Clutch Knobs firmly hand tightened. This will give you a good idea of the maximum tightness (clutch action) that can be achieved by hand effort alone. At this point, you must bear in mind that for optimum performance all three clutch knobs on each axis (R.A. or Dec.) should be tightened evenly to the same tension i.e. all three half tight, all three fully tight, etc.

In order to feel the effect of the clutch knobs, you may wish to partially assemble your mount. Fit together the R.A. and Dec. Assemblies plus mounting plate and counterweight shaft. Do not put scope and counterweights on at this stage. With the above assembly (with the clutch knobs firmly hand tightened - "as shipped"), you can feel the amount of force needed to move each axis by hand. Grab each end of the telescope mounting plate and move it with a backward and forward movement of the Dec. Axis. You will feel considerable resistance to this motion. Perform the same operation on the R.A. Axis by moving the counterweight shaft backward and forward. With a well-balanced telescope, the above tightness of the clutch knobs will be sufficient for all normal conditions of use.



Now, if you proceed to mount up and balance your telescope, you can "feel" what this resistance in R.A. and Dec. (movement backwards and forwards) is like when you make these motions from the eyepiece end of your telescope as you would during normal use when slewing (pushing) by hand to acquire an astronomical object within the field of view of your finder or scope.

3. How tight can the clutch be and can you do any damage by pushing against them?

The clutches can not be damaged by tightening; however, it is not necessary to tighten them as you would tighten the lug nuts of your car's wheel. You will see that each clutch knob has a 5/32 hex socket for tightening with a hex key. With an extra 1/3 turn beyond hand tightening on each clutch knob, the axis (axes) will be considered completely "locked up" and you should not attempt to push your scope by hand against this "locked up" resistance, or undue stress will be placed on the worm wheel / worm and bearings.

Naturally, if you have a very heavy load, it is advisable to tighten the clutch knobs more than is necessary when a lighter payload is mounted. When imaging you'll want to ensure that the clutches are tighter so that there is no slippage. Some recommendations follow.

4. How do the Clutch Knobs of the 1600GTO differ from all 900 and 1200 mounts?

The 900 and 1200 mounts were designed with Delrin clutch plugs beneath the knobs. While these were quite effective as a clutch material and did not damage the underlying worm wheel surface, over time the base of the clutch plugs spread out after being tightened with greater force than necessary, preventing their full release.

The 1600GTO uses a different clutch system, and it also uses a different bearing system for the free rotation of the axes. It will feel stiffer than the 900 or 1200 series mounts.

You should be aware that the clutch knobs on the 1600GTO have spring-loaded tips that may still be applying pressure to the clutches, even though the clutch knobs feel loose. Back the clutch knobs off by at least two or three full turns to more fully disengage the clutches. There will always be some friction. The 1600GTO clutches can be fully tightened without worry.



# BALANCING THE TELESCOPE

To achieve the best performance from your mount, your telescope should be well-balanced. This is more important for imaging setups than for visual setups since greater precision is required for guiding. Those who are setting up for visual use or casual imaging need only be “adequately” balanced, as the mount’s drive system is very robust.

Common sense dictates that you want to begin the balancing procedure with your setup counterweight heavy so that the scope does not suddenly leap from your hands and spin around into the pier. As long as the counterweight is down, sudden movements of the Dec. axis cannot cause a damaging mishap. You will want to perform the balancing with the scope set up exactly as it will be used. Eyepieces, diagonals, finder scopes, cameras, guiders, etc. should all be in place before you begin.

## Preliminary Balancing

1. With the counterweight shaft down and the scope pointing toward the pole (Park 3), loosen the Dec. clutch knobs (about 3 to 4 full turns) and feel which way the scope’s weight is offset. Placing a hand on each end of the scope and lifting back and forth will give you a good feel for balance. Slide the scope (in its rings or via the dovetail) until it feels balanced, then point the scope to the north again and tighten the clutches.
2. Next, loosen the R.A. clutch knobs (about 2 to 3 full turns) and, while holding the counterweight shaft, move the axis into a horizontal orientation. You will probably need to rotate the Dec. axis a bit so that it also assumes a horizontal orientation. Place a hand at the end of the shaft and on the scope and, lifting back and forth, make counterweight adjustments to equalize the balance as well as possible.

This degree of balancing will be sufficient for those who wish to have some fun doing visual observing with family and friends. **DO NOT** disengage the gearbox for rough balancing. **Disengaging the gearbox on an out-of-balance system can damage the worm gears!** If you are planning to do long-exposure, deep-sky imaging, then you’ll want to refine the balance. The steps below will walk you through precision balancing.

## Precision Balancing

Do the preliminary balancing first using the clutches! (see above) Remember that dangling cables will dramatically change balance and create guiding problems, so you’ll want to be sure that all cables are carefully secured and not dragging before you proceed with precision balancing. Ensure that your focuser is in its focused position, the dew shield extended with the dust cap removed and the diagonal with eyepiece or the camera equipment installed. Think: Ready-to-Image!

The counterweights should ride high on the counterweight shaft. It is best to add counterweights and slide them to the top of the shaft with the heaviest at the top and then use the smallest weight to perform the final precision balancing. The reason for this is called “Inertial Moment Arm”. Sliding less weight down the shaft will balance the scope, but will greatly increase the moment arm force; that is to say, it will require a much greater torque to start the axis rotating. (Think of a tightrope walker using a long rod to stabilize his balance.) This is a very important consideration when you are trying to do precise guiding. See illustration at right.

Note that with previous designs of mounts we recommended slightly offset balance to the counterweight side of the R.A. axis and slightly offset balance to the camera side of the Dec. axis. This is no longer true with our current self-adjusting motor box design. **Balance should be as exact as possible when imaging. Balance Dec. and then R.A.**

We also **DO NOT** recommend using an ammeter to balance the mount. At the level of precision balance, friction differences and other factors will completely overwhelm the contribution to current draw made by imbalance.

## Disengaging the Worm and Worm Wheel for Precision Balancing

**The new motor / gearbox design allows complete disengagement of the worm from the worm wheel allowing the axis to turn freely for careful balancing.** It is important to begin with the scope approximately balanced since it will be free to abruptly spin when the gears are disengaged. You definitely do not want the scope to yank from your hands and crash into the pier! Important: Start this process in the safe Park 3 position - dangerous swings are avoided.

On the following page is a pictorial sequence that shows how to disengage the gears. It is as easy as flipping a lever!

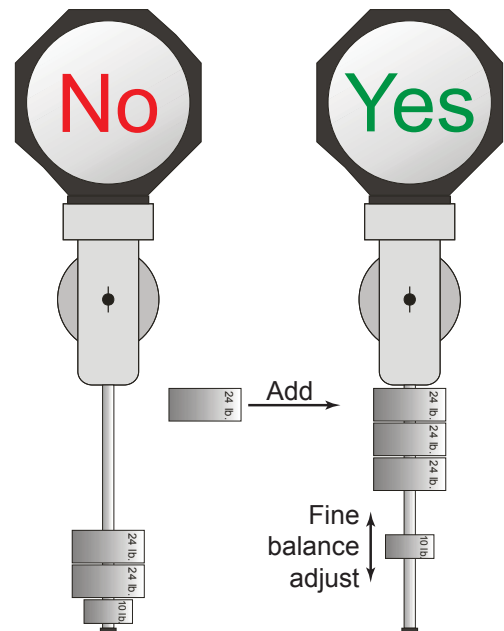



1. Grip the lever assembly cover and pull it free to expose the lever inside. There are grooves on either side of the cover to assist with your grip.
2. Rotate the lever 180° to disengage the worm (never force it past its limits). When you rotate the lever, the motor gear-box will tilt and disengage the worm from the worm wheel. **Caution: The axis will spin freely when disengaged.**
3. When balance is complete, *gently* turn the lever halfway until the spring engages the gear teeth. Shift the axis back and forth slightly to ensure that the teeth have fully engaged.
4. Once the teeth have fully engaged the lever can be rotated fully into place and the cover replaced. **Do Not force the lever! No never! Not ever!**

**VERY IMPORTANT: Begin the balance process in Park 3 position so that there is not an abrupt swing of an out of balance scope which can damage the worm wheel teeth!!!**

#### **Ok...Let's balance!**

1. Be sure that a preliminary coarse balance has been done so that no unexpected swings of the scope take place. Be sure that the clutches are tight on both axes. You will not use the clutches to balance the mount.
2. **R.A. Axis** – Release the gear mesh in the R.A. axis as described in the pictorial above. While holding onto the counterweight shaft, swing the shaft to a horizontal position either east or west to your convenience.
3. Slide the heavier weights to the top of the shaft and try balancing with just the lower, lighter weight. If you must, slide the weights lower as necessary to balance, however, it is better to add another heavy weight up high. The balance should be precise for good guiding when imaging.
4. Position the axis horizontally and then gently turn the lever to re-engage the worm and worm wheel as described above. You may need to slightly rotate the axis so that the gears drop into mesh before fully engaging the lever.
5. Once the lever is fully in its locked position, replace the cover and move on to the Dec. axis.
6. **Dec. Axis** – Release the gear mesh in the Dec. axis as described in the pictorial above. While holding one end of the scope, swing the scope into a horizontal position.
7. Loosen the tube mounting rings or the dovetail saddle locking knobs and position the scope so that it is perfectly balanced and stable in a horizontal position. Remember that the camera should be in its focused position for accuracy. The balance should be precise for good guiding when imaging.
8. Position the axis horizontally and then gently turn the lever to re-engage the worm and worm wheel as described above. You may need to slightly rotate the axis so that the gears drop into mesh before fully engaging the lever.
9. Once the lever is fully in its locked position, replace the cover and you are finished. Now you can loosen the clutches and reposition the scope into a reference Park position so that you can power up and be oriented.

# BALANCING SIDE-BY-SIDE

In a nutshell, this is what you should do. If you are careful about following this procedure without shortcuts or “guesstimates”, you will save a lot of time and effort in the long run. When people look at the procedure and say, “Heck with it, I’ll just wing it,” they usually end up sorry!

The key is preparation! You are balancing 3 systems. Do ALL of this on a worktable, preferably with a helper.

1. Balance the first system.
  - a) Fully assemble one of the telescope systems you will be using. This includes, but is not limited to:
    - i) The dovetail for that scope.
    - ii) The rings or other attachment medium.
    - iii) The complete imaging train including all adapters, correctors, telecompressors OAGs etc.
    - iv) All guiding hardware, if it will be on this system.
    - v) Any finders or other devices.
    - vi) Any special wiring harnesses or electronic devices.
    - vii) Dew Heaters and controllers.
    - viii) ANYTHING that will be attached to this system!!
  - b) Adjust focus as close as possible to where it will be for imaging.
  - c) Place a dowel rod under the mounting plate to create a seesaw. BE CAREFUL!!
  - d) Using the dowel rod as a fulcrum, find the exact balance point of the system.
  - e) Mark the exact balance point with a piece of blue painter’s tape.
2. Balance the second system.
  - a) Basically, repeat the above steps.
3. Since the two parallel dovetail saddle plates are probably somewhat offset, we need to next balance the side-by-side plate trio FRONT TO BACK first.
  - a) This should just be the bottom transverse dovetail plate and the two parallel saddle plates that are bolted on top. Nothing else.
  - b) Run the dowel rod lengthwise under the bottom dovetail plate. Try to keep it parallel with the transverse plate.
  - c) Balance the trio of plates front to back on the dowel rod.
  - d) Mark each saddle plate at the point where it balances over the dowel.
  - e) Remove the dowel rod.
4. Attach each scope system. Simply line up the tape balance points on each saddle with the tape balance points on each of the parallel saddles.
5. Now place the dowel rod back under the bottom dovetail plate, but this time it is perpendicular to the dovetail (parallel to the OTAs).
  - a) Rock the system back and forth until you find its balance point.
  - b) Mark the bottom dovetail with tape at the exact balance point.
6. Put the entire system into the primary saddle plate. This plate will have limited adjustment because it is fixed by its mounting holes. The final part of this is the trickiest.

- a) Our saddle plates offer several mounting options. Look at the setup in front of you and decide which set of mounting holes will best serve your needs.
  - b) Mark the center of the mounting hole pattern that you will be using with tape. This may not necessarily be the perfect balance point.
7. Place the dowel rod under the center of the mounting hole pattern.
  8. Now, adjust the bottom dovetail in the saddle until the system is balanced above the dowel that is in the center of the Dec mounting hole pattern.
  9. Mark the saddle and bottom dovetail so you know exactly where the dovetail needs to be positioned.
  10. Take everything apart, but **DON'T LOSE THOSE TAPE PIECES!!**
  11. When you reassemble, simply line up your tape pieces and 95% or more of your Declination side-by-side balancing will be done.
  12. Final note: When balancing RA, more weight higher up on the shaft is better than less weight further down the shaft.

If the preliminary work is done carefully, you will blow anyone away who might be watching you. Most experienced observers shake their heads when they see someone trying to set up a side-by-side system because they know how hard it can be to get the thing properly balanced. It is very satisfying to put the pieces together and have near perfection right from the get-go!

# ALTITUDE AND AZIMUTH ADJUSTMENTS – ROUGH POLAR ALIGNMENT

It is recommended that you not attach the RAPAS until you have roughly centered Polaris through the sight hole.

For rough polar alignment, your goal is to sight the celestial pole when looking through the polar alignment sight hole. You will need to make altitude (up/down) and azimuth (side-to-side) adjustments to the position of the mount.

*[An inclinometer and a compass adjusted for magnetic declination at your location (or these functions on a smart phone App) can be very helpful for daytime setup. In addition, be sure to learn the Daytime Polar Alignment Routine as described in the keypad manual. It is a great method for rough alignment!]*

**Note on Bubble Levels:** It is possible to achieve perfect polar alignment without having the pier level, but it is slightly more difficult. With a pier that is not level, each adjustment in azimuth also causes a minor shift in altitude and vice versa. This is why we have included the bubble level on the 1600GTO. However, don't waste time obsessing about having the pier perfectly level. This is, after all, NOT an Alt/Az mount! Devote the time to the actual polar alignment instead. If you are reasonably close to level, you will not be able to notice a difference. Keep in mind that unless you are a serious astrophotographer or imager, "perfect" polar alignment is not critical.

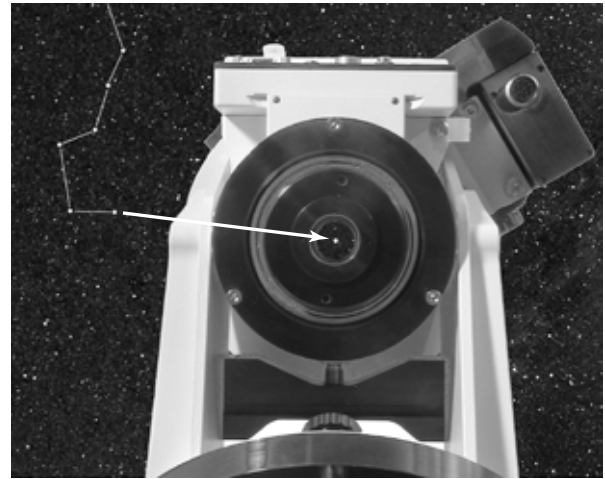

Sighting Polaris through  
Polar Alignment Sight Hole (900GTO shown)

1. Remove the Dec. axis sight hole cover, to complete these steps. Examine the polar axis assembly and you will see that the center of the R.A. shaft is hollow.
2. **Azimuth adjustments:** To begin, move or turn the entire pier or tripod east or west until the mount is oriented approximately towards the pole (an imaginary line drawn through the hollow shaft). Next, use the two fine azimuth adjustment knobs, one on each side of the mount, to make adjustments. You must back off the opposing azimuth knob in order to move the other knob in that direction.

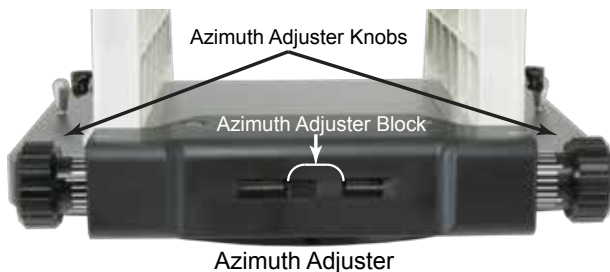

**One full turn of the azimuth knob is approximately 0.3733 degrees (22.4 arcminutes). Small graduations are 0.74 arcminutes; long graduations are 3.7 arcminutes.**

The best adjustment technique to use with the Astro-Physics Azimuth Adjuster, with its clear registration marks for fine adjustment, is to back off one of the knobs by a set amount (a certain number of registration marks) and then to turn the other knob until you re-establish contact on both sides of the Azimuth Adjuster Block. You can very precisely zero in on the desired position with no backlash or ambiguity on the position. You can also always go back to the precise starting point if for some reason you overshot your mark (or if you adjusted the wrong way), because you know exactly how far you've gone. This is explained further in the section on Fine Polar Alignment.

3. **Altitude (latitude) adjustments:** Loosen the Altitude Lock Knobs. Move the polar axis up or down with the large Altitude Adjustment Knob located in the front of the polar axis assembly. We have found that using the turnbuckle on the north leg of our pier also can make fine altitude adjustments, if used.

**One turn of the altitude knob is approximately 0.41 degrees (24.6 arcminutes).**

4. Continue your azimuth and altitude adjustments until you center Polaris in the polar alignment sight hole. At this point, you have achieved a rough polar alignment, which may be sufficient for casual visual observations. When the R.A. motor is engaged (the power is plugged in), it will compensate for the rotation of the earth and keep the target object within the eyepiece field of view. If your target object slowly drifts, you can make corrections with the N-S-E-W buttons of your keypad controller.

5. Tighten the Altitude Lock Knobs by hand.

# POLAR ALIGNMENT OPTIONS – FINE POLAR ALIGNMENT

For casual visual observation, you may skip this section and simply start observing. A finder-scope or single power finder may be required to locate objects since GoTo slews with the keypad require good polar alignment for spot-on accuracy. Don't forget to tighten your Altitude Lock Knobs (4) before you begin! For casual visual observation, you can move the telescope manually via the clutches or by using the GoTo and centering functions of the keypad.

The keypad and GTO Servo Control Box will function as soon as they are plugged in. That means that the R.A. axis will be moving westward at the sidereal rate. Note, however, that this motion will not be accurate enough to qualify as "tracking" without accurate polar alignment. In short, if you will depend on the GoTo functions of the 1600GTO, or if you intend to do astrophotography, you must perform a more accurate polar alignment. Some methods, procedures and tips are presented below. You will complete this alignment when your scope and other equipment are mounted.

## Methods for fine polar alignment

- **Polar Alignment Scope** – Our optional Right-Angle Polar Alignment Scope (RAPAS) will allow you to quickly align your mount on the pole. The reticles are designed for use in both the Northern and Southern hemispheres. Even users of the GTO computerized mounts will find these polar scopes useful, particularly if your telescope is not orthogonal to the mount (please refer to the keypad manual for a discussion of orthogonality). If you have a polar alignment scope, please read the instructions sheets that come with it. If you are planning long-exposure astro-imaging, we suggest that you use the polar alignment scope, then tweak the final polar alignment by using traditional drift alignment, the GTO Quick Star-Drift Method (refer to the most recent Keypad manual), *PEMPro™* Pole Align Wizard or other similar alignment program.
- **GTO Keypad** – Please refer to the instruction manual for the GTO Keypad for a discussion of the various options. Here are summary descriptions of several techniques for polar alignment from the current Keypad Manual for v4.19.5 available from the Technical Support page of our website.

- The Daytime Routine (see "Polar Aligning in the Daytime" in the Keypad Manual), is a great trick for daytime setup. It will allow you to "wow" your friends by setting up and finding planets and bright stars in the daytime. In addition, it is the recommended first step in alignment for anyone in the southern hemisphere. Even those in the south who own our polar scope will find it helpful, since it will generally put the rather difficult-to-spot southern stars into the polar scope's field of view.
- Roland's GTO Quick Star Drift Method - 2020 version outlined in the appendix utilizes a finder scope or imaging camera which enables you to make precise polar alignment via a couple of meridian flips.

Using the Daytime Routine, followed by the GTO Quick Star Drift Method will provide accurate enough polar alignment for extensive imaging. This combination is our recommended procedure for anyone in the southern hemisphere, or anyone who finds their view of the pole obstructed.

- The Keypad startup routine of the v4.19.5 (or earlier) version provides two additional methods: North Polar Calibrate and Two-Star Calibrate. These two polar alignment methods, though no longer recommended, were developed for quick and coarse alignment in the field with portable setups. They are for visual observers, not imagers. The Two Star Method is the better of the two as it is less affected by the extremely low resolution in R.A. near the pole and by orthogonality issues.
- **Computer Software Solutions** –
  - Polar Align via PEMPro's "Pole Align Wizard" – PEMPro™ is a software by Ray Gralak and distributed by CCDWare. This powerful application not only analyzes and improves the periodic error performance of any mount that is equipped with a CCD camera and compatible camera control software, but also includes "Pole Align Wizard".

"Pole Align Wizard" is one of the best methods of accurately polar aligning! It is like traditional drift aligning, but on steroids! It has the advantage of automatically choosing the optimized stars for drift aligning and does not have to worry about star magnitude since the CCD can see dimmer than an eye. Also, it compensates for air refraction and other variables that manual drift aligning cannot. It does require the use of a CCD camera and corresponding camera control software. The Wizard walks you through the alignment process with easy step-by-step instructions. A full PEMPro™ edition is included with the 1100GTO, 1600GTO and 3600GTO mounts (sorry, not the Mach1GTO or Mach2GTO).
  - Other Software – There are many software packages that include aids to polar alignment that can be found through a Google search. Some will work better than others. Do not be fooled into thinking that your alignment is perfect simply because a piece of software told you so. Polar Alignment is, after all, entirely a mechanical issue. Apart from "Pole Align Wizard", we do not have experience with these other software programs and cannot vouch for them or provide support.

- **GTO Quick Star Drift method** – Traditionally, this very time-consuming procedure has been regarded as the most accurate method of polar alignment. However, if you are using the old method of drift alignment that employs stars near the eastern or western horizon, you may encounter problems from atmospheric refraction, which will skew your alignment. To obtain more accurate results, choose stars somewhere near the celestial equator due south or slightly east and west, but not below 45 degrees elevation.

For portable setups, we believe that using the Keypad with our GTO Quick Star Drift Method that utilizes the Meridian Delay Feature of the Keypad and a Finderscope (found in the keypad documentation as noted above) is a much more practical approach in terms of providing highly accurate alignment and still leaving enough time to actually get some imaging done. A permanent observatory setup where long unguided exposures are taken may still benefit from a final tweaking using the traditional star drift method (as modified by the 45 degree elevation recommendation above) or from a software enhanced variant like the *PEMPro*<sup>™</sup> Pole Align Wizard that allows a CCD to measure and calculate the drift much faster than can be done at the eyepiece.

- **DRIFT ALIGNMENT - R.A. CORRECTION METHOD** – This will provide the highest precision of polar alignment with the least amount of drift within 45 degrees of the zenith (where most imaging is done). Please see the Appendix and Support page of our website for the instructions to this alignment technique. **Note: This and the “Pole Align Wizard” are the preferred alignment method when tweaking the RAPAS orthogonality.**

## ***Making Precise Altitude and Azimuth Adjustments***

The mechanics of altitude and azimuth adjustment are relatively straightforward. In the discussion below, we will provide some information and tips that will give you the greatest success with your 1600GTO regardless of the polar alignment method you choose for determining the amount and direction of each adjustment. We'll leave the choice of method up to you. (Did we mention the GTO Quick Star-Drift Method?) We list the fine altitude adjustment first because our GTO Quick Star-Drift Method begins with altitude. Many texts for the classic star-drift method begin with the azimuth adjustments.

When you made your rough alignment earlier, you loosened everything up, got the mount close, and then tightened everything back down. Any minor shifting that occurred from locking things down tight was of no consequence since it was a rough procedure. Now you are fine-tuning the alignment. Regardless of whether you start with altitude or azimuth, begin the fine adjustment process with **everything** locked down as if you were already finished. Then, loosen only what is required to make the adjustment, and loosen as little as possible. Your final adjustment should always be with everything virtually, but not quite fully locked. It may be helpful to use the technique of tightening the knobs a little more with each new adjustment.

### **Fine Altitude Adjustment**

Slightly loosen the four Altitude Lock Knobs, but do NOT loosen the polar axis pivot screws. Move the polar axis up or down with the large Altitude Adjuster Knob located in the front of the polar axis assembly. If lowering the axis, you may need to “help” the axis down if your lock knobs are somewhat tight. If you lower the axis, always be sure that the axis remains in firm contact with the stainless steel thrust pad. Please refer to the illustrations earlier in this manual if you are unsure about these parts. It is also possible to make fine altitude adjustments by using the turnbuckle on the north leg of our pier, if used. **Final adjustment should always be made pushing up in altitude.**

**One full turn of the altitude knob is approximately 0.41 degrees (24.6 arcminutes).**

### **Tips for Adjusting the Altitude**

1. The mount's polar axis is held in place between the two side plates. It is possible for the mount to shift slightly when the locking knobs are fully tightened down after adjustment of the altitude angle. To prevent this shift, it is suggested that the initial fine altitude adjustment be done with these knobs hand snugged, and as you approach the final adjustment point, tighten the knobs, first to hand tight, and finally with a hex key after each small movement. As you converge on the pole in altitude, each successively smaller adjustment is made against greater resistance from the ever tighter lock knobs.
2. Approach the pole from below and try not to overshoot. If you accidentally move the axis too high and overshoot the altitude angle, it is better to loosen the four lock knobs a bit, and bring the axis back down a very small amount before proceeding back up with the knobs tightened up again. This way you are using the weight of the mount to insure a solid connection to the altitude adjuster. The “captain's wheel” design of the Altitude Adjuster Knob provides the necessary leverage during the final “tweaking” adjustment phase when the locking knobs are quite tight.

## Fine Azimuth Adjustment

The one-piece Azimuth Adjustment assembly makes for easy and accurate polar alignment in your observatory or in the field, and it eliminates issues of adjustment backlash. The heavy-duty construction and integrated one-piece design result in smooth control of the azimuth axis. Large left and right adjuster knobs are graduated for precise control of azimuth position angle.

**The small graduations are 0.74 arcminutes per graduation; long graduations are 3.7 arcminutes per graduation; one full turn is 0.3733 degrees or 22.4 arcminutes.**

The size of the knobs makes them easy to turn with very little torque required, even with the mount fully loaded. Take full advantage of the graduation marks on the Azimuth Adjuster when performing fine alignment to mark your starting and ending points for each adjustment. This will allow you to exactly undo any adjustments that are made in the wrong direction. Do not leave the knob you have backed off loose. When finished, both knobs must be tight against the azimuth adjuster block to hold the azimuth angle you have set. If you follow our hint below, the act of adjustment will leave the adjusters tight against the azimuth adjuster block!

**Important Hint:** The natural tendency when making azimuth adjustments is to first back one adjuster knob off a significant amount, then make the required azimuth adjustments with the other knob, and then when finished, to tighten the first knob back up against the azimuth block. This can result in a slight shift as the first knob is tightened against the block. We recommend that you completely abandon this approach for fine azimuth adjustment.

Instead, we recommend that you start with both knobs tightened against the azimuth adjuster block. Then, ***back off the first knob only by the small amount of the adjustment you plan to make.*** Use the graduated markings on the knob to mark your starting and ending points. For example, if you are already pretty close, you might try backing off just two small graduations, or roughly 2 arcminutes. Finally, make the actual adjustment by tightening the other knob thereby making the tiny adjustment you required and eliminating any shift because everything is already tight when you are finished. By using the graduations, you can easily undo any errors or estimate the magnitude of your next adjustment.

## Precision-Adjust Rotating Pier Base with Azimuth Bearing

Under normal circumstances, the Precision-Adjust Rotating Pier Base does not require adjustment. However, you may, on rare occasions, need to adjust these screws to gain the proper feel during the adjustment process.

The Precision-Adjust Rotating Pier Base consists of two plates that allow ultra-smooth adjustments for critical polar alignment. Notice the two Delrin screws on the underside of the Precision-Adjust Rotating Pier Base. They are located at the “NW and NE” positions. These screws are used to apply tension to the rotating plate. If you notice a slight amount of shift, particularly with a larger scope, carefully tighten the screws a small amount. **DO NOT** overtighten! If you find too much resistance, then loosen the screws slightly.



## Using Software to Improve Pointing Accuracy

Software solutions are available today that will help to compensate for orthogonal problems as well as other idiosyncrasies of your telescope, mount and optics. These programs analyze and compensate for these problems, resulting in improved telescope pointing performance. Refer to the documentation for these programs for further information.

- Astro-Physics Command Center (APCC), Pro version with pointing and tracking model. This is the only program that will provide tracking correction and has numerous useful control and safety features. [www.astro-physics.com](http://www.astro-physics.com)
- *MaxPoint™* Modeling Software from Diffraction Limited, [www.cyanogen.com](http://www.cyanogen.com)
- *TPoint™* Modeling Software from Software Bisque, [www.bisque.com](http://www.bisque.com)



## MISCELLANEOUS ITEMS

### ***Bubble Level and Lanyard Post***

We have added a Lanyard Post on each side of the 1600GTO mount. Its purpose is to provide a convenient place to hang the Keypad lanyard during an observing session. Additionally, there is a Bubble Level for your convenience. See *Photo at right*.

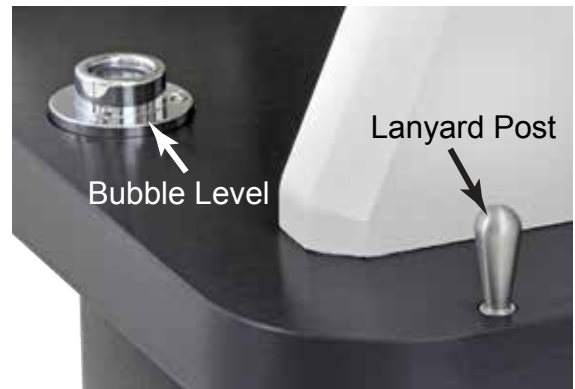

### ***Reference Orientation Lines***

Astro-Physics mounts offer the convenience of utilizing reference positions when setting up. These positions allow you to quickly establish your mount's orientation so that the first GoTo of the evening will be very precise, requiring only a slight corrective ReCal.

Note that both the R.A. and Dec. axes have orientation lines (reference the photo at right) that allow you to position your scope into a Park 2 or Park 3 position from which you can initialize your mount and slew to your first object. You can also position your scope with the R.A. axis for Park 1 and Park 4 (different latitudes will make for variable Dec. positioning).

The Reference Lines will also allow you to quickly resume your position if you've made a manual move with your clutches. However, understand that while the positioning will be very close, it will not have encoder accuracy. You will need to do a ReCal once you arrive at your first object.

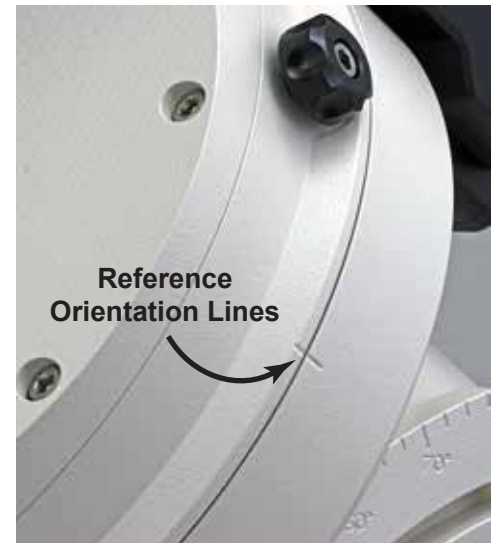

### ***Warning for Dec. Servo Cable***



One of the most important things to remember when disassembling the 1600GTO for transport is to disconnect the Dec. Servo Cable before separating the two axes. We all need a reminder from time to time and so we have posted a decal on the Dec. axis reminding you not to forget to disconnect it. See *Photo at left*.

# ORTHOGONALITY CORRECTION

Accurate GoTos require good polar alignment and minimum orthogonality. Orthogonality errors will cause pointing issues with German equatorial mounts, especially seen when doing a meridian flip that makes the pointing accuracy much worse.

Traditionally, correcting orthogonality (sometimes called "cone error") involves meridian delays and flipping back and forth across the meridian to observe how far from image center that the star falls. This is time consuming and involves trying to remember whether you need to advance or delay the flip time in order to swap sides. Is it east side or west side?... advance or delay?...groan!

Here is a faster method that won't make your head spin.

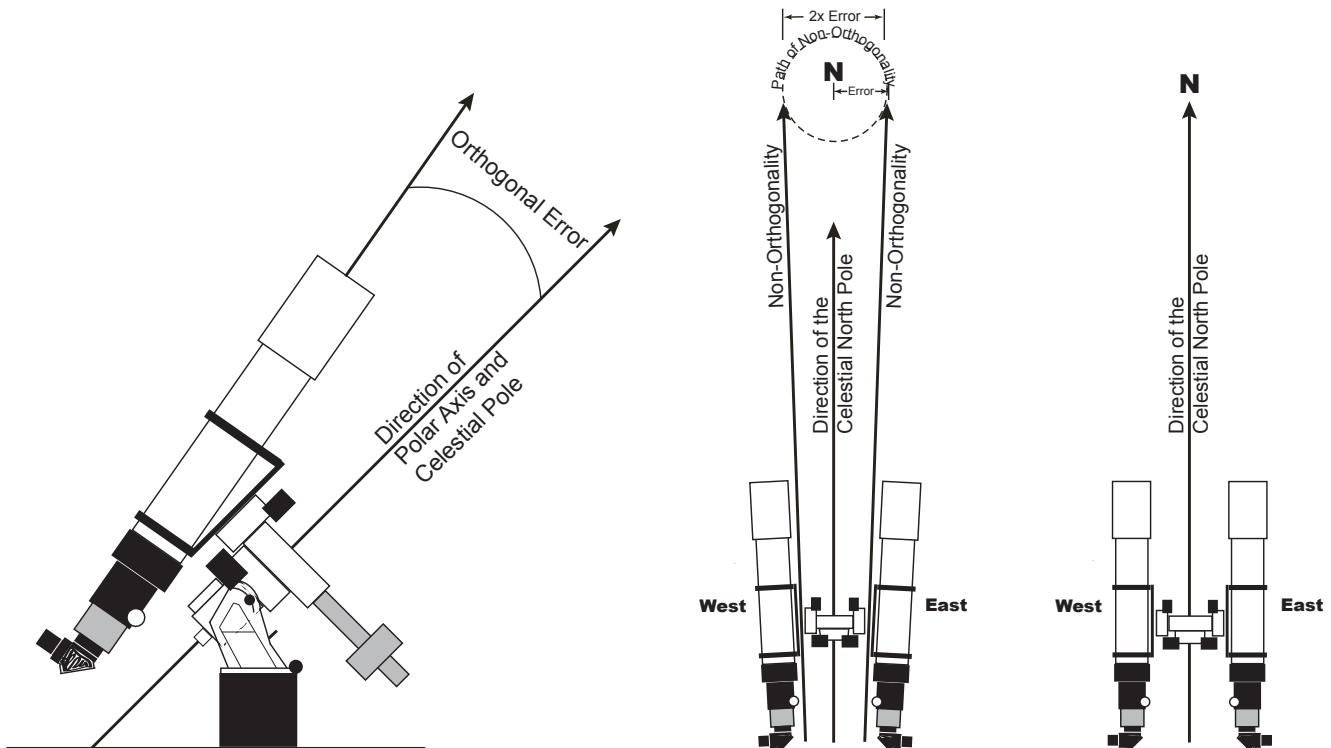

## Step by step (mechanical correction)

- Do a GoTo to Polaris. The star will not be in the center (eyepiece or CCD image) if you have any orthogonality error.
- Put the star as close to center in Dec. with the N-S buttons. You will find that it will not move with R.A. with the E-W buttons.
- Push a bit on the telescope tube in the R.A. direction, you will see the star move either toward or away from the center.
- Determine which way the tube must move to end up toward the center.
- Loosen either front or rear scope ring attachment to the dovetail plate and slip a thin shim under the rings (.005" to .025" as needed).

With the right amount of shim, you can get Polaris exactly in the middle in the R.A. direction while using the N-S buttons to adjust the Dec. direction. You'll be able to go from one side of the meridian to the other and put every object on the chip or in the eyepiece. Elapsed time...about 10 minutes!

## APCC Pro Software

Orthogonality and polar misalignment can also be corrected by using the Pointing and Tracking Modeling found in APCC Pro version. It is always advised to minimize these errors mechanically before making the APCC model. Please reference APCC features and information found on the Astro-Physics website.

# 1600GTO-AE AND 1600GTO-AEL ABSOLUTE ENCODERS

The Absolute Encoder option for the 1600GTO mount can be installed at the factory before shipping or installed later by the user. It provides absolute positioning information, eliminates periodic error and eliminates Dec. backlash. The encoders provide the ultimate in mount perfection.

**When the encoders are installed at the factory they are shipped with the encoders turned on!  
Leave them on. There is no reason to ever turn them off!**

## Additional Parts Included with the Absolute Encoders

- R.A. and Dec. RESA Ring Assemblies, installed
- R.A. and Dec. Readhead Assemblies, installed
- Cable from GTOCP4 Control Box to Interface at rear of the R.A. axis (CAB16AE)
- Screw driver, 1/8" flat (FSDF18)

If you purchased the kit to install the encoders yourself, you will also receive fasteners and complete instructions.

## Absolute Encoder Cable Connections

There is only one external cable (CAB16AE) with its two connectors. This cable connects at the rear plate of the R.A. axis (slot screwdriver required) and runs to the Encoder connector on the GTOCP4 Control Box.

The two photos identify both the Servo Motor cable and the Absolute Encoder cable and their respective connections. (**NOTE:** the exact position of the ports on the Control Box may be slightly different depending on the layout)

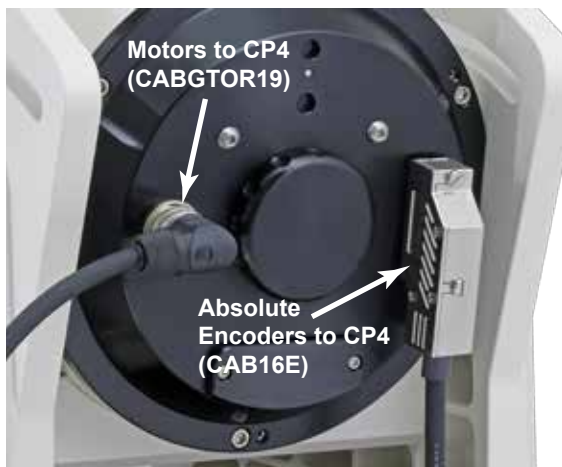

If one orders the Absolute Encoder Kit to be installed on an existing mount, then each Readhead (R.A. and Dec.) will have internal connectors requiring a one-time connection. This will be described in full in the instruction guide that comes with the kit.

## Benefits of Absolute Encoders Summary

The utility of absolute encoders varies from brand to brand. Some manufacturers make very limited use of encoders and use relative (not absolute) encoders to provide a potential benefit to tracking and nothing else. The benefits inherent to the 1600GTO with its premium dual on-axis absolute encoders include:

- The mount always knows where it is pointed regardless of power loss, bumping the mount or wind movement as long as the clutches remain engaged.
- Homing positions can be set to whatever orientation a user wants, without limitation when using APCC.
- No re-homing is required for remote locations should there be a power loss.
- Periodic error is fully corrected. No need for occasional PE measurement curves.
- Zero backlash in Dec. axis for precision guiding.

- Dual-axis absolute encoders allow for variable tracking that automatically adjusts for refraction parameters when using APCC and there is a King rate in the Keypad.
- Very accurate pointing makes it easy to find very faint objects when using APCC or Keypad modeling.
- Very precise tracking such that unguided imaging may be accomplished with an appropriate optical/imaging setup using APCC or Keypad modeling..
- Very precise guiding, if needed, with instant response in both axes. Guiding is only needed to correct for optical/imaging train issues, not mount issues.
- The dual-axis encoders enable the mount axes to accurately respond to your guider software commands down to the 1/10 arc sec level. There is no periodic error to fight; there is no Dec backlash delay to overcome.
- Corrects for polar misalignment and repeatable mechanical flexure when using APCC or Keypad modeling.
- Very precise dual-axis tracking is very important for high-precision tracking on objects like comets, asteroids, and artificial satellites, where the mount uses a “self-guiding” function based on orbital elements.
- Although absolute encoders cannot anticipate wind, they can react to it after the fact. So, you will have excursions but the axis being affected will recover much faster when the encoders are on. The best strategy is to set your mount low to the ground without extending the tripod legs. Large telescope tubes catch more wind than skinny ones. Same with short scopes versus long ones.

# WHAT IS MEANT BY “INITIALIZATION”?

In simplest terms, “initialization” is the process of giving the mount’s servo controller the information that it needs to know:

- Where is it?
- What is the time?
- How is it supposed to operate?
- It then un parks the mount and allows you to calibrate the pointing by using a defined AP park position (if needed).

The above is the information you entered into your software when you first installed and set it up. For keypad users, it is the information you entered when you followed the “First Session with your Keypad” instructions (in the Keypad manual). These four points are detailed below.

1. Latitude and longitude coordinates tell the mount where it is. The GTOCP4 will remember where it was when last powered down, but can’t know if you have moved to a new location unless it is told.
2. Time, date and time zone give the mount the necessary time information. Time information is required to calculate the mount’s current pointing position if it hasn’t been moved, and it is needed to calculate the meridian and the horizons. The mount’s servo does not have an internal battery to maintain time between power-ups, so time is an essential part of every initialization.
3. Commands to establish the tracking, guiding, centering and slew rates along with other similar parameters like PEM tell the mount how it should operate.
4. The command to “unpark” the mount is sent. This command both ends the parked state and it also calculates the mount’s current pointing position if the mount has not been moved manually by hand via loosening the clutches. The decision whether or not to calibrate on a defined AP park position will depend on the circumstances.

For an established setup that has not been moved, do NOT calibrate on a park position. Resume from last parked or last position. The unpark command will have resulted in extremely accurate calculation of the current pointing position without further calibration being necessary.

For new setups, or if you have moved the mount with the clutches, you will need to calibrate on (aka “resume from”) an AP defined park position.

# QUICK START SUMMARY – NEW INSTALLATIONS USING KEYPADS

**This summary gives an outline of the workflow to have a successful first observing session. Enjoy!**

1. Enter the Time and Location data into the Keypad. Follow the instructions in the Keypad Manual for entering your Time and Location data into the Keypad. (Location 1 is usually your primary observing location)
2. Set the Keypad to AutoConnect: NO. This will allow you to choose the location for which you entered the data above. Remember to power cycle the mount after the data has been entered. This will lock the information.
3. Assemble the mount. Reference this mount manual.
4. Balance the system. Reference this mount manual.
5. Polar align the mount – at least roughly. (If using the daytime routine, move this step to after the mount is initialized. If using the RAPAS, do it before initializing.)
6. Place the system into a pre-defined AP Park position for initialization. Reference the positions shown at the end of this Quick Start Guide.
7. Power up the mount; select your location and press GoTo.
8. The next menu has 4 choices. Choose “4=New Setup” and select the Park position that you chose in #6 above. This will initialize the mount and ready it for going to your first object.
9. When you arrive at your first object you may need to use the N S E W buttons to center the object. Do so and then press the RA DEC REV button on the bottom right, followed by the #9 button to do a ReCal of position. The following GoTo slews to other objects should be more accurate.
10. After finishing your night’s observing (or day’s solar observing) it is best to park the mount into your chosen Park position by pressing 2=Setup; then 4=Park / Mount Opt.; and finally choosing the Park position number where you wish to park.
11. Power down the mount.

## Helpful Hints

- “New Setup” is only used when you are setting up the mount for the first time or if you have readjusted scope position via the clutches and wish to restart from a “Reference Position”.
- “ResumeLastPosition” is used when you parked the mount at the end of the previous session and wish to begin a new night of observing. Selecting it will initialize the mount and you’ll be ready to go to your first object.
- If you are in a permanent setup, then you should set the Keypad to “AutoConnect: YES” so that when you power up the mount, it will automatically be initialized and ready to go to your first object. This is the most automated of the setups using the Keypad.

# QUICK START SUMMARY – NEW INSTALLATIONS USING COMPUTERS

**This summary gives an outline of the workflow to have a successful first observing session. Enjoy!**

1. Install and set up your control software and drivers. This can be done before you even take delivery of your mount.
  - a) Set up ASCOM and the drivers first. You will find the URLs for them below and links on the Software Support page of our website. It is very important the you download the latest versions.
    - i) FTDI driver - <http://www.ftdichip.com/Drivers/VCP.htm> This is required for the USB function of the GTOCP4.

- ii) ASCOM Platform - [ascom-standards.org](http://ascom-standards.org)
  - iii) AP V2 ASCOM driver - <http://www.gralak.com/apdriver>
- b) Install third party software (Starry Night, TheSkyX, MaxImDL, etc.)
  - c) Adjust software settings - follow the appropriate workflow documentation in the GTOCP4 manual.
  - d) If using the Keypad along with a computer, set the Keypad to AutoConnect=EXT and power cycle the mount in order to lock in the change.
2. Assemble the mount and add the mounting plate, counterweights, telescope and other accessories.
  3. Balance the system per the guidelines earlier in this manual.
  4. Polar align the mount – at least roughly. (If using the daytime routine, move this step to after the mount is initialized. If using the RAPAS, do it before initializing.)
  5. Place the system into a pre-defined AP Park position for initialization. .
  6. Power up the mount and connect with your primary control software. Use the primary control software to initialize the mount. Start out from the park position chosen in #5 above. Your other initialization settings will have been set already in step #1.
    - a) If using APCC, always start it and connect with it first.
    - b) If the AP V2 Driver is your primary control software, it must be started with a client program.
  7. Connect other software that you will use with the mount.
  8. After finishing your night's observing (or day's solar observing) it is best to park the mount into your chosen Park position using either the AP V2 driver or APCC, rather than Third Party software if you are using a PC for mount control.
  9. Power down the mount.

## WHAT IF I GET LOST?

**Hope is not gone...there are a couple very quick and easy fixes!**

### Manual Fix (when with the mount)

1. Loosen all the R.A. and Dec. clutches so that the scope can be moved freely with your hands. Moving the scope into a Park 3 position will provide additional safety for this procedure.
2. Command the mount to go to Park 3 using either the Keypad or a computer (whichever you have been using for the evening). While the motors are moving, hold the scope with your hands so that it remains safe.
3. When the motors both stop, use your hands and put the scope into Park 3 (use your eyes to get close) and then tighten all the clutches.
4. That's it...you're done! Orientation has been restored to the universe! When you go to your first object you'll need to adjust the centering and then do a ReCal, but your initial slew should be close.

### Remote Fix (requires APCC)

1. Park mount in Park 3 position and click the Home/Limits tab or AE tab (if absolute encoder mount)  
*This must be done when setting up the mount and when it is calibrated with the night sky.*
2. **Home/Limits Tab:** Click the Configure Home and Limits button and choose Current APCC Park Position box (recommended) and click Set Home Position button.  
*This establishes mount gear angle and will allow "lost" mount to be recovered even through power cycles.*
3. **AE Tab (Absolute Encoder Mounts):** Click the Configure Home button (under Find Home) and follow instructions. In the Configure AE Home window that appears after the Calibration warning it is recommended to choose the Current

APCC Park Position (Park 3 is recommended). Continue following the instructions.

4. If the mount becomes "lost", then clicking the Find Home button will send the mount to the established Park 3 Home position and recalibrate the mount. You will then be able to continue your night's observing.

**Important Note: Once the above Home Positions have been set you MUST NOT loosen the clutches and move the mount by hand. If that is done, then the Home positions will need to be re-done!**

## SLEWING YOUR MOUNT IN BELOW FREEZING TEMPERATURES

There are several potential problems when slewing your mount in below freezing temperatures. The symptoms are a wavering or chattering sound from the motors, a slowing down of the slewing with a sudden jolting stop at the end of the slew, and in the worst case, a continuous running of the motors and loss of control. The following are four suggestions to alleviate the problem:

- First, in cold weather it takes significantly more power to slew the motors than it does in the summer. This extra current drain can cause a voltage drop in the power cord running from the supply to the GTOCPx control box. It is therefore especially important that you not use extension cords between the mount's cord and the DC power source. If you must have a long distance between the supply and GTOCPx control box (unavoidable in some observatory situations), use a heavy wire to minimize the voltage drop.

If the power drops below about 10.5 - 11 volts at the servo terminal, the internal computer chips may reset with subsequent loss of control of the motors. If your supply is marginal, it may also not produce the voltage necessary for proper operation during slews. It is a good idea to limit the slew speed to 600x during real cold weather to reduce the power demand from the supply.

- Second, it is very important to have a properly set worm mesh and to not have it set overly tight. One symptom of an overly tight worm is a chattering sound as the motors try to slew at 1200x or even as low as 600x. You can check to see if the worm turns easily by removing the motor covers and then rotating the large aluminum spur gear. Try turning it by hand one full turn in each direction. If it does not easily turn, then the motor will also have a difficult time turning it. Check in our technical section of the AP web site to learn how to set the worm mesh.
- Third, under extreme cold temperature conditions (below -20F) it may be necessary to replace the grease on the worm wheel teeth with a lighter material. We are currently using a custom mixed grease which has a very wide temperature range and promises to be effective even during these cold temperatures. We have Grease Kits available. We have tried straight low temperature greases that work to -80F, but in each case the worm gears get abraded very quickly.
- Fourth, we recommend using a 15-16 volt power supply (or equivalent) for heavier loads. We have found that the higher voltage improves motor performance when operating under these adverse conditions. Do not exceed 16 volts.



# AUTO-ADJUSTING GEARBOX - NO MORE WORM MESHING!

The good news is that your mount is always in mesh, thanks to the Auto-Adjusting Motor Gearboxes! The 1600GTO mount represents a new era in the ease of gearbox adjustment. Our new design eliminates the need for gear mesh adjustment. It has become automatic. Spring pressure holds the worm screw in perfect mesh with the worm wheel at all times.

The only adjustment that may ever need to be made is to re-set a backstop...and that is rarely needed if ever.

## Checking and Adjusting the Gearbox Backstops in R.A. and Dec.

This is a very easy and quick process. It is also a process that you should almost never need to do. Many mounts will go several years or longer without the need to tweak this backstop. Adjusting this backstop is about the only way that you can actually mess up your gear mesh. So, approach with caution. (Tool needed: 5/64" hex key)

1. **Put the mount into a Park 3 position.** This is important to ensure that there is not uneven pressure on the gears due to an out of balance load. Be sure that the mount is powered off. Park 3 is counterweight shaft down and scope in line with the R.A. axis, pointing toward the pole.
2. **Remove the Lever Assembly Cover.** Grip the cover and pull it straight out.
3. Make sure the lever is in its normal position - snapped in place, parallel to the respective axis.
4. **Loosen the Lever Assembly screws.** Using a 5/64" or 7/64" hex key, loosen the two screws (#1 in the illustration) so that the assembly is freed to move. This should require less than one turn of each screw.
5. **Apply a slight pressure to the lever assembly.** Using your index finger and thumb as shown, apply a very gentle pinching pressure to shift the assembly towards your thumb (the backstop only needs to touch). This sets the proper backstop position.

**Important:** DO NOT push on the gear box itself when adjusting the backstop. Pressing on the rear of the box can cause the box to pivot out of mesh and give a bad adjustment. Pressing on the top of the box will push the box into tighter mesh and would cause excessive tightness and damage to the worm wheel teeth.

6. **Tighten the screws.** While maintaining the slight pinching pressure, snug and then tighten both screws. Do Not Overtighten.
7. **Replace the Lever Cover.** Replace the cover and you are finished. It is that simple!
8. **Repeat with the other axis.** Repeat the process with the other axis, if necessary.



## What to do if you believe that there is a backlash in the gearbox

- First, if you think that there is a worm gear mesh issue, you are probably wrong. If you think there is backlash, it is almost certainly from a different source, so check these possibilities first.
  - Check the mesh of the spur gear reduction set. With your thumb and forefinger gently attempt to move the middle spur gear back and forth. There should be a slight amount of movement so that the gears do not bind up; however, it should be slight. If there seems to be too much looseness, contact Astro-Physics for further help.
  - Check to be sure that the two shoulder bolts that secure the spur gears are snug. Important: the bolts should be snug...Do Not Overtighten, as they can break or damage the gears.
  - Check that the entire motor/gearbox is securely fastened to the axis housing. There should be a very small amount of front-to-back rocking that is possible due to the spring loading mechanism, but there should be no discernible side-to-side movement. If you feel side-to-side play, contact Astro-Physics
- **IMPORTANT!** Do the following with the mount powered ON. It should be UNPARKED and tracking should be STOPPED. There are two or three small screws securing the worm spur gear to the worm. A screw may be obscured by the top gear. For that reason the mount is powered on so that you can rotate the gear using the direction buttons at 12X or 64X. If you turn the R.A. gears by hand, you will lose your PE correction; therefore use the direction buttons.
  - Check that the worm's spur gear is securely attached to the worm shaft. The 2 screws must be tight. (Be careful, however! They are small screws, not automotive lug nuts!)



# REMEMBER THESE TIPS

- **When using Mounts with Auto-Adjust Motor Gearboxes:**
  - **Use the clutches when repositioning the mount!** This is a safer practice than using the gearbox disengagement lever in order to ensure that the gear teeth are not damaged by accident. Refer to the section regarding clutch operation.
  - **Begin your balance procedure in Park 3 position (pointing to the pole).** This will ensure that an out of balance scope does not have a sudden, wild swing that could damage the scope, the mount or you!
  - **Be sure that the Gearbox engage/disengage lever is fully disengaged and that the worm is fully separated from the worm wheel when balancing the mount (or moving the mount when repositioning)!** It is important not to damage the tops of the gears by bumping the worm and worm wheel teeth!
- **Be careful not to twist and inadvertently damage internal cables.** It is important to remember not to twist and damage internal cables by over-rotating the axes. If the axes are rotated when setting up or performing mount maintenance, you will need to undo the axis rotation to return cables to their normal position. Internal cables should not be pulled tight; rather, they should be left slack and free to move.
- **Be sure that all fasteners on the mount and scope are tight.** You do not want to have to catch a falling scope or see it sitting unexpectedly on the concrete!
- **Computer and Keypad use together.** If you are using a computer for primary mount control, but wish to have the Keypad connected for convenience while at an eyepiece, then set the Keypad to AutoConnect: EXT so that the computer will initialize the mount, not the Keypad.
- **Always Initialize and park the mount using the same device.** If you initialize with the Keypad, then park with the Keypad...if you initialize with the computer, then park with the computer. **Important Note:** If the Keypad is your chosen method of operation, then uncheck the following two boxes in the AP V2 driver's Setup Telescope...1- Sync Mount to PC Time and 2- Keep Mount Time Synced to PC Time.
- **Unpark from Last Parked.** If the mount is being re-started from a previous night, as in a permanent observatory or at a week-long star party, then unpark from Last Parked (assuming that the scope has not been repositioned manually by hand via the clutches since it was last parked).
- **Unpark from a defined park position.** If your equipment is being set up afresh for a night's observing, then place the scope in a defined park position and have it unpark from that specific position. If it is to remain set up for the next night, then park it to your position of choice and resume from Last Parked the next night.
- **GTOCP4 Control Box will auto-park mount when powered off.** The GTOCP4 control box will auto-park the mount in place when the power is turned off or is interrupted. Nevertheless, we do recommend parking the mount to a convenient park position when finishing the evening's viewing (and leaving the mount set up for another night).
- **Use the mount with its own power supply.** For best performance the mount should have its own power supply. This is especially true when imaging.
- **Reference the Astro-Physics Technical Support page of the website.** There is a wealth of information on the Technical Support page that can often answer the questions that you have, as well as provide in-depth understanding and fixes. All the latest versions of the manuals can be found on the page.
- **Remember that the answer to most questions can be found in the supplied manuals or on the website.** Please reference these manuals or the website Technical Support before calling Astro-Physics. If you cannot find the answer, then the Technical Support team is ready to help.

## Please take special notice:

- **Outdoor Storage** – If you have a mount that is left outside for extended periods covered by a tarp or scope cover, then it is highly recommended to remove the GTOCP4 and Keypad and take them inside to a safer environment. Tarps and covers cause significant condensation build up unless steps are taken to mediate the problem. Often low wattage light bulbs or fans are used to reduce condensation for short term storage, but this is no guaranty.
- **VERY IMPORTANT:** We take every precaution to make our control boxes moisture and dew resistant; however, they are not waterproof! We cannot be responsible for water damage when reasonable care has not been taken to shield them from excessive dew or when storing them outside under tarps for extended periods.

# MOUNT CARE, CLEANING AND MAINTENANCE

Like any fine piece of equipment, your mount's longevity and performance are directly correlated with the quality of the care that you give it. Handle it with respect, keep it as clean and dry as is practical, and perform a few minor maintenance tasks, and your 1100GTO will give you many years of trouble free service.

## Care

Although we build it to be rugged enough for field use, your 1100GTO is a precision instrument with very accurate worm and wheel adjustments. Please be careful if you place the mount on a flat surface, i.e. the ground or trunk of your car. The gear alignment may be affected if the R.A. and Dec. Motor / Gear Box assemblies sustain undue lateral force. This is true of any fine instrument. We suggest that you transport and store the mount in a case or in a well-padded box. ALWAYS disassemble the mount before moving it or transporting it. More damage can be done in a few careless seconds in transit than in many hours of normal operation.

Try to keep your mount protected from dust and moisture when not in use. In warm, humid weather, be aware of the dew that may have formed on the mount while in the field and allow the mount to dry out before packing it away for storage once you get home. On the other hand, if it is cold and dry outside, keep the mount packed up when you bring it into the house until it reaches room temperature to avoid "fogging it up." (The same advice applies to telescopes, eyepieces and other equipment in your Astro-arsenal.)

## Cleaning and Touch-up

Wipe your mount clean with a soft dry cloth. If needed, you can use a damp cloth or a cloth that has been sprayed with a mild, non-abrasive cleaner (window or all purpose cleaner – no bleach). Do not spray cleaners directly onto your mount. If you use a cleaning product, follow with a damp cloth to remove the chemicals from the mount.

The painted surfaces of your mount may end up with scuff marks from repeated transport and assembly / disassembly. Most of the time, these marks can be removed with a product like *Color Back™* by *Turtlewax™* (automotive product). Simply apply with a paper towel and buff out the mark. If your paint becomes chipped, touch-up kits are available for purchase – please call us.

*NOTE: Paint touch-up kits can only be sold to U.S. customers due to regulations governing shipment of hazardous materials.*

## Counterweight Appearance

Stainless steel is resistant to oxidation, but over time its appearance can degrade. Applying a good car wax coating will help to maintain the pristine stainless steel finish of your counterweights.

Should cleaning need to be done, it is recommended to use an SOS detergent pad to clean the weights. Be sure to dry them thoroughly, and then follow up with the car wax.

## Routine Mount Maintenance

Under normal operating conditions, minimal maintenance is required. If the R.A. and Dec. axes are attached together for a long time in outside conditions (i.e. in a permanent observatory) then the mating surfaces should be lightly oiled or greased - if you expect to get them apart again after 10 years.

Jostling and vibrations associated with transport to and from observing sites has had the effect of causing screws and fasteners to work their way loose over time. We have worked very hard in both the design and assembly of our mounts to alleviate this problem, but it is still a good idea to periodically (once or twice a year) inspect and if necessary re-tighten any easily accessible fasteners. Additional maintenance information can be found below in the troubleshooting section and in the Technical Support Section of our Web site.

## Worm Wheel Maintenance

Using the entire worm wheel ensures even wear and extended life. Under normal use the mount moves back and forth using only one half of the worm wheel...the other half is not used.

Here's what to do: Send the mount to Park 1, unlock the clutches and push the mount to Park 4. Lock the clutches and then power cycle the mount (power off and then on). Tell the mount to resume from Park 4. The mount will then be using

the other half of the worm wheel. This procedure does NOT alter your PE correction.

Note that it will be necessary to have the Keypad set to AutoConnect=NO (if initializing with the Keypad) or to set the AP V2 driver / APCC (if initializing from the computer) to Unpark from Park 4. Once this operation is done remember to reset to Unpark from Last Parked.

Do it twice a year...that should be enough.

IMPORTANT! If you have an encoder mount, you MUST reestablish your Home and Limits.

## ***Greasing Mount***

We have designed access ports for periodic greasing into the 1600GTO. One is located on each axis. By opening the port, you'll be able remove the old grease using a toothbrush and soft cloth to brush and wipe away the grease while turning the axis to fully reach the entire gear. The gear wheel can be advanced to another section by simply moving the mount east or west at slew speeds via the directional buttons. Similarly, the new grease can be applied by brushing it into the gear while turning the axis.

All 360 degrees of the worm can be accessed that way, even with the mount fully loaded with counterweights and telescopes. No need to tear down a permanent setup to do this maintenance.



Contact our office for a Grease Kit (GREASEM) of custom mixed greases and complete set of instructions for regreasing the main gears and spur gears. Frequency for greasing will depend on mount use and environment. Greasing every year or two will maintain your mount for life.

***Special Note: Doing a full greasing of the spur gears will require running a new PE curve.***

# **TROUBLESHOOTING, TIPS AND SUPPORT**

## ***Troubleshooting and Tips***

Additional troubleshooting questions are in the GTO Keypad or GTO Servo System manuals. Some of the issues discussed in these manuals relate to mount communication issues whether you use the keypad or control the mount with a planetarium program or *PulseGuide*<sup>™</sup>. Please refer to them.

**The Declination (or R.A.) axis does not turn freely, even with the clutch knobs fully loosened.**

The design of the clutches is such that spring loaded tips always maintain some friction against the worm wheel. Consequently, the axes will never spin freely. Back the clutch knobs off by at least two or three full turns to more fully disengage the clutches. There will always be some friction. The 1600GTO clutches can be fully tightened without worry.

**The LED on the GTO Control Box changes from red to yellow and the motors stop or go out completely (for control boxes shipped after 02-25-00).**

1. The voltage of your battery has probably gone below 10.5 volts.
2. The current rating of your AC-DC power supply is too low.

**Note:** The most common problems are due to inadequate power supply! Voltage must be measured while under load.

*Additional explanation:* During slewing under load, the two motors draw up to 3 amps from a 12-volt source. This may increase when the temperature approaches freezing or below. It is recommended that your supply be rated at a minimum of 12 volts DC at 5 amps continuous. 12.3 to 16 volts with a capacity of 5 to 10 amps is recommended for best performance. (Do NOT exceed a nominal 18 volt system.) See the Power Considerations section beginning on page 29)

If you also power other equipment (CCD cameras, dew heaters, etc.) from the same source (NOT recommended!), you will need a supply capable of up to 10 amps. The more equipment you have, the more current capability you will need.

We always recommend giving the mount its own supply and using additional supplies for other equipment.

For portable applications, we recommend heavy-duty deep-cycle batteries designed for deep discharge applications (i.e. marine, golf cart, fork lift, or wheel chair batteries).

3. The motors are overloaded, probably due to an unbalanced load on your mount.

Rebalance your telescope, and then press one of the N-S-E-W buttons to reset the keypad. Re-enter the last object on your keypad and the scope will slew to the correct position. Even though your motors had stopped, the logic in the control box retained the scope position in memory. As long as you didn't change the pointing position of the scope, you are still calibrated.

If the scope was moved during re-balancing, simply enter a nearby bright star on the hand controller, press GOTO and allow the mount to finish slewing. You can then move the scope manually or with the N-S-E-W buttons to center the star in the eyepiece, and press the #9 RECAL button. This will recalibrate the mount.

*Additional explanation:* The GTO drive circuit includes logic for overload protection to prevent burning out the expensive servomotors in case of severe overload on the two axes. The primary cause is an unbalanced load in R.A. If the extra load opposes the motor rotation, the motor must work harder to track at the sidereal rate and the current will rise to high levels. If the current exceeds the trip point for more than a minute, the logic will shut the motor off and tracking stops. It typically takes about 4 lb. of unbalance to trip the overload, but a very heavy load of scopes, accessories and counterweights on the mount can decrease this unbalance threshold.

### **The keypad reset (or locked up) when I plugged my CCD camera, PC (or other equipment) into the same battery as the GTO mount was using. The battery has a meter, which shows 12V.**

The meter is reading an average and will not show dips. Gel cells have internal resistance, which will cause voltage drop when the load changes. When you connect an additional CCD camera and PC the load will drop below 9 volts and the keypad will reset or it may affect the GTO circuit itself and cause the keypad to lock up.

We recommend that you use a large marine battery that is not a gel cell and hook everything up to it before calibrating the GTO. Or, better yet, put the other equipment on a separate battery.

### **What is the maximum voltage that I can use to power the servo drive?**

Please refer to the Power Considerations section of the GTO Servo Motor Drive System manual.

### **For polar alignment, I am using declination drift technique with stars on east & south. Now, I do not see any drifts in declination on both sites (E & S), so the mount "should" be properly aligned. However, I have still small drift in R.A. which looks like the R.A. motor is a bit faster than earth rotation. This drift is something like 1.5 arcseconds during 1 minute or so & accumulates over time, so it doesn't look like periodic error.**

The sidereal tracking rate is exact in the mount (it is crystal controlled and checked here for accuracy). However, the stars do not move at exactly the sidereal rate everywhere in the sky. The only place they move at that rate is straight overhead. As soon as you depart from that point in the sky, the stars will be moving more slowly, especially as you approach the horizons. Thus, it looks like the mount is moving slightly faster than the sidereal rate. Just because you have done a classic drift alignment, does not mean that the stars will now be moving at the sidereal rate everywhere in the sky.

In order to increase the area of sky from the zenith that will give you fairly good tracking, you will need to offset the polar axis by a small amount. The amount will depend on what your latitude is. The other approach is to vary the tracking rate for different parts of the sky. Ray Gralak's Pulse Guide will allow you to dial in an exact tracking rate for any part of the sky.

The Astro-Physics Command Center Pro (APCC) includes tracking and pointing correction based on calculations from atmospheric refraction all the way up to sophisticated real-world models based on plate-solve data for your specific instrument package.

### **Initially, the mount was working fine. Then, suddenly the mount stopped tracking altogether!**

Chances are that the motor was turning properly and driving the worm gear, but that your clutches might have been loose and therefore the scope was not following the motion of the worm gear. The fact that the high slew rate did move the scope does not change this, because Roland has seen this himself where the tracking rate did not overcome the slipping clutches but the slew rate did.

If you are unsure of the motion of the motor, just remove the motor cover plate and look inside. You will see the motor turning. Sometimes when you have the clutches loosely engaged and the counterweights are somewhat out of balance, being heavy in the east, then the clutches might slip at the slow sidereal rate.

In any case, just to set your mind at ease, simply remove the motor cover next time something like this happens and look at the motor shaft. If the motor is not turning, you will have some kind of electrical problem. If it is turning, then it is mechanical.

### **The motors sound louder and more labored in cold weather.**

As the temperature drops, we recommend that you reduce your slewing speed to the slowest slew rate. The cold causes the lubricants to get stiff in the gearboxes. This can make the high-speed gears resonate and sound screechy. Lowering the slew speed in winter will eliminate or reduce this. You might also want to add a drop or two of light machine oil to the center posts of the individual gears. Just remove the cover on the gearbox and add the oil drops. The noise is nothing to worry about. Refer to the section of this manual entitled: Slewing Your Mount in Below Freezing Temperatures.

### **The declination axis does not appear to be moving properly. How can I check it?**

Please refer to the section of this manual entitled: "Characterizing the Dec. Axis Motions," which explains how to use Diffraction Limited's *Maxim DL*™ software to characterize your mount's performance.

### **When I press the E button on my keypad, it takes forever for the star to finally stop.**

First, the problem is most often caused by the worm and worm wheel not being in mesh (this is often the case when a used mount is purchased and the previous owner never ever adjusted the worm mesh or the mesh was altered during shipment). When the worm is out of mesh, it takes the motor many seconds to reverse the tooth contact from leading to trailing edge because it is running at the very slow sidereal rate. Backlash adjustment is very easy to accomplish on the 1600GTO that has the Auto Adjusting Motor Gearboxes. Please refer to the section in this manual entitled: "Gear Mesh in the 1600GTO".

### **I am experiencing trailed stars after a slew and apparently a high, variable backlash.**

Check to make sure that the spur gear that is attached to the end of the worm is not loose. A loose screw will indeed cause the axis to delay during reversal. In a few cases, we have seen that the set screw on this spur has backed off and needs to be retightened. If you have any doubts about where this worm and spur gear is in the scheme of things, call Astro-Physics and we will talk you through the procedure to check this.

Remember this: Any backlash or looseness in Dec. will NOT cause trailed stars after a slew. That is because the Dec. axis does not move once it gets to its new position, so no trailing is possible. So, if you are getting trailed stars for a short time, don't look for something in the Dec. axis.

However, the R.A. Axis WILL cause trailed stars after a slew if the spur gear is loose. That is because this axis must move at the sidereal rate immediately after getting to the new position. If the spur gear is loose on the worm shaft, it will turn slowly at the sidereal rate without imparting this motion to the worm itself (because it is slipping). At some point, the set screw will catch on the edge of the flat on the worm shaft and begin to drive the worm gear. So, this looks like classical backlash, when in fact it is not backlash at all, and all attempts at setting the gear mesh on the worm are futile to correct this lost motion.

When we get a chance, we will post a complete set of pictures on our website showing how to check for this loose gear condition. Meanwhile, you can take the cover off the motor gearbox and acquaint yourself with the spur gears inside. Do not be afraid to move and wiggle things by hand to see how stuff works.

One more thing, sometimes a person will be absolutely certain that it is the Dec. axis that is giving him a problem because the CCD program he is using shows some improper function in the Y-axis, and he is absolutely certain that Y = Dec. After much sending of equipment back and forth to our facility, it finally is determined that it was the other axis after all that had the problem. PLEASE, please make sure that you have identified the proper axis. In the case of any kind of motion problem like this, it would be really helpful if you removed your camera, inserted an eyepiece with crosshairs and actually looked to see what was happening. You can then identify exactly which direction, R.A. or Dec., is moving after a slew. Sometimes because of mix-ups in the CCD software (*MaxImDL*™, for instance), the axes are identified backwards.

When you are trouble shooting, remember, R.A. is the only axis that must move at the sidereal rate and is the only axis that can trail a star if it is not moving correctly at that rate. The Dec. axis does not move after a slew and will not trail a star except by a very slow long period drift due to polar misalignment, etc. It will not trail a star image EVEN if it has 10 degrees of backlash, so that analysis is definitely suspect.

## I'm having a frustrating guiding problem with my mount and need to figure out my next steps.

To begin with, the directions represented by the X+, X-, Y+ and Y- in your guiding software do not necessarily correspond to any given cardinal directions. To the guiding software, "X" and "Y" simply refer to the rows and columns of pixels on the guide chip – nothing more.

The act of calibration tells the guiding software how to relate a guide star's drift along the columns and rows to move directions in the mount, but it does not make it so that X is necessarily always right ascension and Y always declination. To further complicate this, each time you alter the camera's orientation, you effectively change the relationship between X / Y and R.A. / Dec.

Your very first step in diagnosing any type of guiding problem should be to determine the actual current relationship between the X and Y of the guiding software and the R.A. and Dec. of your mount. This is easily done in your guiding software by making a manual move in one axis during an exposure and comparing this to a guide move from the keypad (use the keypad – not your computer software!) where you know the axis and direction for certain.

We have seen customers waste countless hours (not to mention dollars) in trying to fix a guiding problem on an axis that was performing perfectly. Meanwhile, their true problem remained, all because of this axis mix-up.

Your next step would be to remove the camera and place a high power eyepiece with crosshair reticle into the focuser. Then sit down and watch what happens to the guide star. With the eyepiece and reticle, you can see whether or not the mount is tracking smoothly and how the periodic error is manifesting itself. Yes, you will have periodic error, and any good CCD camera will pick it up to give you oval stars - that is a given. What you need to find out is whether this periodic error is within limits ( $\pm 3.5$  arcseconds for the 900GTO and 1100GTO and  $\pm 2.5$  arcseconds for the 1200GTO and 1600GTO) and whether it is smoothly varying. You can also do some hand guiding using the 4 buttons on the keypad. It will tell you how responsive the mount is to your guiding inputs and may even show some hidden problems when you try to keep the star on the crosshairs.

Alternately, you can use *PEMPro™* (the full version of *PEMPro™ is included with the 1600GTO*) to characterize your periodic error. It will tell you things like the peak value and the smoothness of the error.

You can also characterize your mount tracking and guiding abilities using the "Characterizing the Dec. Motions" test outlined in the Technical Support section of our AP website and included in the back of this manual. Many times a problem guiding in R.A. can be the result of a Dec. axis mechanical problem. Not knowing this, you will be forever chasing down the problem on the R.A. axis, and never reaching a solution. Characterizing your Dec. axis will at least show you that the mount reacts properly to the 4 guide directions. If it shows a problem area, then at least we will know how to fix it.

Once you know that the mount is tracking in a normal fashion with normal periodic error profile, you can go from there to begin setting up your guiding parameters. It is not a piece of cake to get an autoguider to work flawlessly. It is an art, but once you know that the mount responds properly to the guide inputs, it should be possible to set it up to work accurately.

## Additional Support

For additional information regarding the 1600GTO, refer to the Technical Support Section of our website. We also encourage you to participate in the ap-gto Yahoo user group. The members of this group are very knowledgeable about the operation of their mounts, CCD imaging and other related issues. The staff of Astro-Physics also participates and you will find a wealth of information in the archives. To find the group, link from User Groups in our website's sidebar.

If any problems occur, please don't hesitate to contact Astro-Physics for assistance.

We encourage you to submit your technical support questions directly to Astro-Physics by phone or e-mail: [support@astro-physics.com](mailto:support@astro-physics.com).

We may add additional troubleshooting tips to future versions of this manual or in a separate technical document. In such an instance, we would add this information to the Technical Support section of our website as well.

**ASTRO-PHYSICS, INC**  
11250 Forest Hills Road  
Machesney Park, IL 61115  
Telephone: (815)-282-1513  
Fax: (815)-282-9847  
[support@astro-physics.com](mailto:support@astro-physics.com)  
[www.astro-physics.com](http://www.astro-physics.com)



## APPENDIX A: PRE-DEFINED PARK POSITIONS

**Recommended:** **Park 3** is a safe and balanced position. **Park 2** is a convenient position for loading and unloading your scope. **Park 5** is a safe, low profile position with minimum cable twisting.

### **PARK 3**

**Northern Hemisphere  
&  
Southern Hemisphere**

*The scope is pointing to the pole. The counterweight shaft is pointing down.*

*RA axis is vertical, Dec = 90*



### **PARK 2**

**Northern Hemisphere**

*The scope is level on top of the mount facing the eastern horizon. The counterweight shaft is pointing down.*

*Both Hemispheres: RA axis is vertical, Dec = 0*

*The southern hemisphere is mirror reversed. The scope still points to the eastern horizon, but east is to the left when facing the southern pole.*

**Southern Hemisphere**



## **PARK 5**



### **Northern Hemisphere**

*The scope is level on the east side of the mount, facing the northern horizon. The counterweight shaft is also level and pointing due west.*

*on the east side of the northern horizon. shaft is also level*

*Both Hemispheres: RA is horizontal,  
North: Dec = (90-Latitude) South: Dec = (-90-Latitude)*

*The southern hemisphere is mirror reversed. The scope is still level on the east side of the mount, but is facing the southern horizon.*

*The counterweight shaft is also level and pointing due west.*



### **Southern Hemisphere**

**Park 1 and Park 4 are no longer recommended** : Park 1 and Park 4 positions are still available from the Keypad and APCC software. However they are not recommended, and included only for backwards compatibility. When unparking from Park 1, the mount moves into a counterweight up position in a short time, and can cause issues with subsequent GoTos. Park 5 is recommended as the alternative to Park 1. Park 4 points any attached instruments (such as camera, filter wheel, etc.) away from the rear of the amount, and can often cause issues with excessive cable lengths or strain. Park 5 is also recommended as the alternative to Park 4.

## APPENDIX B: DRIFT ALIGNMENT – RA CORRECTION METHOD

What you need: CCD guide camera, computer with program that will give you a guiding graph.

Classic Drift Align minimizes only Dec drift over most of the sky. However, that results in significant RA drift at the zenith. Drift in RA increases the closer you are to the Earth's equator. Why was this classic method of drift alignment developed? It was developed this way because in times past, most equatorial mounts had only right ascension drives and no way to adjust declination drift. If you could eliminate Dec drifting, all you needed was a drive corrector for the RA motor that would allow you to adjust the RA drive rate to compensate for the RA drift; you had a fairly nice unguided system and could take images.

However, since most of our imaging is done from 45 degrees to the zenith, we will benefit more from this RA Correction Method.

### ***Several Things to Keep in Mind***

- Before you begin you will want to level the mount so that as you make adjustments in either azimuth or altitude; adjusting one will not affect the other.
- Make sure that all aspects of your mount and scope are tight (rings, scope and mount fasteners, focuser and camera, etc.). If you are using a mirrored scope, be sure that the mirror is locked (if available) to minimize flex and flop.
- You must make the azimuth adjustment first so that you can then make the altitude adjustment accurately; otherwise, the azimuth adjustment will change your altitude setting and it will have to be re-done.
- The altitude adjustment must always be finalized by pushing upwards against gravity with the locking knobs quite snug (not to be further tightened). If you overshoot, then you should loosen the knobs and lower the altitude and repeat the upward adjustment.

### ***Procedure***

1. Begin by having your mount polar aligned by a polar scope or other method.
2. Align your CCD guide camera to be square with the R.A and Dec axes of your mount. Know which axis is RA and which is Dec. Assume nothing...test it. Unless your mount has absolute encoders, make sure that PEM is turned on with a good PE curve. PE correction is not needed when using absolute encoders.
3. Go to a star near the celestial equator / meridian and start guiding.
4. Set your guiding aggressiveness to 0%.
5. Open your guiding graph and watch only the drift on the Dec line. Using the azimuth knobs, adjust the mount's azimuth until the star stays on the line and does not drift up or down. Don't worry about what is happening on the RA line, just zero out drift on the Dec line.
6. Once that is done, go to a star near the zenith (usually on the East side within 1/2 hour of the meridian).
7. This time you will watch only the RA line on the guiding graph. Adjust the mount's altitude knob (only pushing upward) until the star stays on the line and does not drift. If you overshoot, loosen the altitude locking knobs; lower the altitude; re-tighten the knobs and start again. Remember, your guiding aggressiveness is set to 0%.
8. Done this way, the two adjustments are independent and don't interfere with each other. The adjustment can be done in about 20-30 minutes. Repeating steps 1-6 will allow refinement and confirmation.

What you will end up with is no RA and no Dec drifting at the zenith. This near zero drift zone will extend approximately 35 to 40 degrees in either direction, giving you a 4 hour drift-free window for imaging. Depending on focal length and pixel scale, you might get round stars in a typical 10 - 20 minute exposure as much as 45 degrees from the zenith.

So, you can do drift alignment either way: align on the pole with classic drift alignment or align on the refracted pole with the RA method. The former will minimize Dec drift over a large area of the sky; the latter will minimize RA and Dec drift at the higher parts of the sky where most imaging takes place. Everywhere else you will need to guide.

## APPENDIX C: ROLAND'S GTO QUICK STAR DRIFT METHOD - 2020 VERSION

What you need: Keypad or APCC to provide Meridian Delay function and a cross hair from either a finder or computer program (like Maxim DL).

### ***Azimuth Alignment***

This first section will describe a precise way to polar align the mount's azimuth. Once that is done, it will not require any further adjustment. The idea is to use the natural geometry of the sky with respect to an earth-bound mount to produce a perfectly aligned azimuth. That's the axis that rotates the bottom of the RA axis east and west.

Concept: If the scope is pointed straight at the zenith on either the west or east side of the mount, that point will remain stationary as you rotate the azimuth axis. So, if a star is in the eyepiece at that point and you bring it to the center of a cross hair, you can rotate the azimuth axis and the star will stay on the cross hair - at least for some minutes if you are tracking it. However, if you then slew to a star down south along the meridian line, it will deviate either east or west depending if the azimuth axis is too far west or east. The star at the zenith is then a pivot point, and the star down toward the south is your calibration star (or azimuth adjustment star). Bring that one to the cross hair by turning the azimuth adjusters and you are theoretically perfectly polar aligned.

So, the simple routine goes something like this:

1. Roughly polar align using any method that gets you close.
2. Using your planetarium program, pick a star near the zenith on one side of the meridian. Roland likes to use a star in the west with scope on the east side. That way it won't migrate across the meridian while doing this alignment step.
3. Bring the star to the center of a crosshair and do a ReCal. MaximDL has a nice crosshair if you want to use an imaging camera for this alignment.
4. Now pick a star down toward the south near the meridian line and on the SAME SIDE of the meridian (or north if you are in an upside down hemisphere), and slew to it. The star will appear either east or west of the crosshair, so now just turn the azimuth adjuster until the star is on the center-line of your crosshair. It may or may not be aligned N-S (in Dec) but that is of no consequence. No ReCal is necessary because you did not move to it via the motors.

Basically you are done with azimuth, but you can re-check by slewing back to the first star and do these 3 steps again for more precise alignment.

### ***Altitude Adjustment***

1. Slew to a star near the meridian (within an hour), center the star N-S on a cross-hair and ReCal. Ignore E-W offset.
2. Using Meridian Delay (using a Keypad or APCC), enter the same star and enter GoTo which will flip the scope to the other side.
3. Now simply bring the star 1/2 way to the cross-hair via the altitude adjuster and the rest of the way via the N-S buttons (again ignore E-W offset).
4. Press ReCal and you are basically done.
5. You might watch the overhead star drift and maybe tweak the alignment a tiny amount, if at all.
6. This method is usually good enough for 5-minute exposures with an 800mm focal length scope.
7. You can repeat this by going back-and-forth a few times repeating this process, but it should be quite accurate the first time. If you have floppy optics, it may not converge.

# APPENDIX D: DECLINATION AXIS BACKLASH TESTS

## PulseGuide™

PulseGuide™ is a free software program, developed by Ray Gralak, to provide keypad-like functionality using a computer. It offers the additional feature of a Dec. axis backlash test. You can download it from Ray Gralak's website.

Once you have started the PulseGuide™ application and have connected to the mount, go to the "PEM/other" tab and click the "Backlash Tests" button to bring up three tests suggested by Roland Christen to test the performance of your declination axis. Roland posted some tests that you can run on your AP mount to see if it has a potential problem with Dec movement.

**IMPORTANT: Before running tests 1 and 2 set the mount's backlash to 0. Also while performing the tests do not try to auto-guide.**

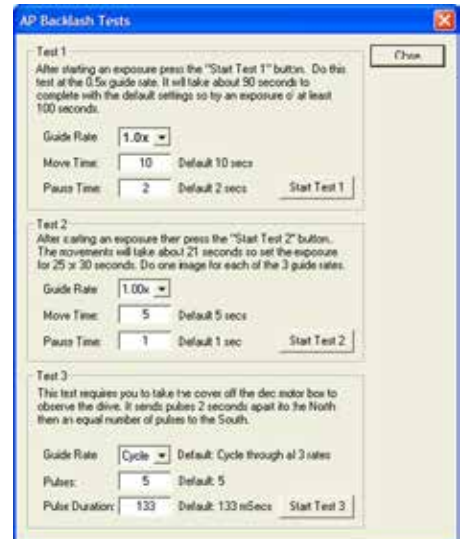

### Dec Backlash Test 1

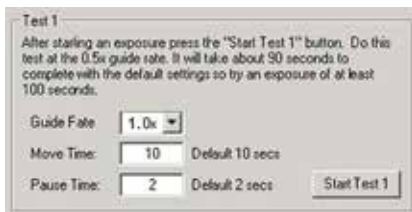

Before starting Test 1 set up your camera control program (e.g. *MaxImDL™*, *CCDOps™*, etc.) to do a 100 second exposure (but do not autoguide). You can also set up an auto-dark exposure, but make sure that you start the test when the camera control software is exposing the light image.

Once you start the exposure press the Start Test 1 button. With the default settings (recommended) the entire procedure will take about 90 seconds.

Test 1 will move the scope in this manner: East - pause - West - pause - East to center - North - pause - South - pause - North to center.

The stars in the resulting exposure should look something like the image to the right. The scale might be different but you should see what looks like many plus signs in the image.

If you take the image near Dec=0 the height and width will be about the same. Although not shown in this particular image the East and West points will be slightly brighter than the North/South points. This will make it easy for Roland to establish the orientation of the camera.



### Dec Backlash Test 2

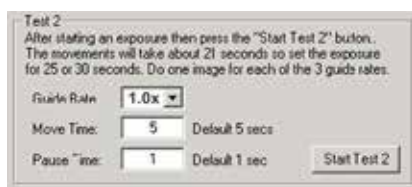

You will run Test 2 three times, once for each of the guide rates. Before starting this test set up your camera control program (e.g. *MaxImDL™*, *CCDOps™*, etc.) to do a 25 second exposure but do not try to autoguide. You can also set up an auto-dark exposure, but make sure that you start the test when the camera control software is exposing the light image.

Start by setting the Guide Rate to 1x. Once you start the exposure press the Start Test 2 button. With the default setting (recommended) the entire procedure will take about 16 seconds.

Although the scale might be different, the stars in the resulting exposure should look something like the image shown.

**0.5x**



For reference the actual movement in Test 2 is: North+West - South+West - West only (the pause setting) - North+West.

**0.25x**



Now you will need to repeat the tests at 0.50x and 0.25x. The star patterns will look similar but smaller because the movement rate is slower. Here are two examples taken with a Traveler:



## After Running Tests 1 and 2

If you see star patterns different from the above images then crop a bright star in each of the four images and save them as a high-quality JPEG. Please make sure to “stretch” each image appropriately so that it is not too dim or overexposed. If you do not know how to stretch and create a jpeg then save the cropped image in FITS format.

Then send the 4 files (preferably zipped to save bandwidth) to Roland at: [chris1011@aol.com](mailto:chris1011@aol.com).

After submitting these tests, AP will advise you if anything appears anomalous and if so what can be done about it.

## Dec Backlash Test 3

This test moves the declination motor at regular intervals to check that the gears move properly.

To do this test you will need to remove the cover from the declination motor housing (contact Astro-Physics for directions if you need).

The Guide Rate combo-box has 4 choices: 0.25x, 0.50x, 1.00x, and Cycle. You can choose a specific rate or Cycle to have *PulseGuide*™ repeat the test at each rate.

While watching the uncovered declination gears click the Start Test 3 button. *PulseGuide*™ will send 5 pulses spaced 2 seconds apart (or however many you entered in the Pulses edit box). Each pulse will of the same duration – that which you enter in the Pulse Duration edit box. The default is 133 milliseconds. Watch carefully to make sure the pulses look evenly timed and that the fastest moving gear moves equally each time.

Once all pulses have been sent in one direction, an equal number of pulses are sent in the reverse direction. It is normal on reversal of direction that there is a slight delay in movement because of backlash. If this happens you may wish to increase the pulse count. If you see erratic movement please contact Astro-Physics for instructions.



## MaxImDL™

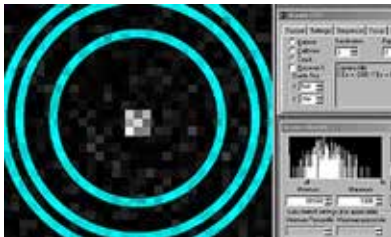

### Step 1

Acquire a reasonably bright guide star and begin guiding in R.A. only - turn off Dec. guiding. Use a 1 second or faster refresh rate so you can see the motion of the guide star as you begin to move it around. Magnify the screen to 1600x and place the cursor in the middle as shown. Check to make sure that the mount is guiding adequately in R.A. and that the guide star is not bouncing around due to poor seeing. Best results will be achieved when the R.A. guiding is 0.5 pixels average in R.A.

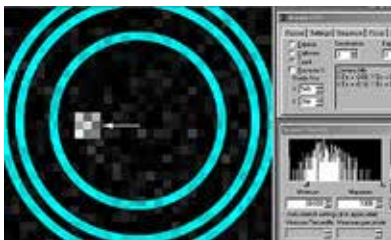

### Step 2

Put the keypad button rate at 1.0x. Press the keypad North button until the guide star has moved approximately 6 pixels from the center. Now press the South button in very short pulses and note which direction the star moves. It should move back toward the middle after a few button presses. It might move slightly up or down, or it might continue to move further away from the middle, or any combination. Please note exactly how far, and in which direction, the guide star moves (pixel position is displayed in the guide box at right in Maxim).

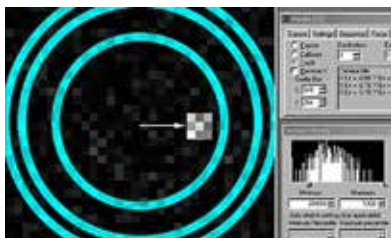

### Step 3

Press the South keypad button until the star has moved 6 pixels off the center in the opposite direction. Repeat Step 2 and note exactly the motion of the guide star as you move it with the pulsed motion at 1.0x.

You may wish to enable Track Log to record the numbers for further study. Please note on the log what you did at what time so the results will be useful later.

# APPENDIX E: MOUNTING PLATE FASTENER CHART

A-P Part #	Description	Ships with:
<b>FP1500</b>	15" Flat Plate	(4) 1/4-20 x 5/8" SHCS [for mounting to 400, 900 or Mach1] (4) M6-1.0 x 20mm SHCS [for mounting to 600E] (4) 1/4-20 x 3/4" SHCS [for mounting to 1100, 1200, & 1600]
<b>FP1800</b>	18" Flat Plate	(6) 1/4-20 x 1" FHSCS [for mounting to 900, 1100, 1200 or 1600] (4) 1/4-20 x 1-1/4" FHSCS [Mach1]
<b>DOVELM2</b>	8.5" D-style Dovetail Saddle for Losmandy D-style Plates for 400, 600E, Mach1, 900 and 1100 Mounts	(4) 1/4-20 x 5/8" SHCS [for mounting 400 or Mach1] (4) M6-1.0 x 20mm SHCS [for mounting 600E] (2) 1/4-20 x 5/8" FHSCS [for mounting to 1200] (4) 1/4-20 x 3/4" SHCS [for mounting to 900, 1100, 1200 or 1600] [or to attach to SBD13SS or SBD16SS]
<b>DOVEDV10</b>	10" Dual-style Dovetail Saddle for Losmandy D-Style and Vixen V-Style Plates for 400, 600E, Mach1, 900 and 1100 Mounts	(4) 1/4-20 x 5/8" SHCS [for mounting 400, Mach1, 900 or 1100] (4) M6-1.0 x 20mm SHCS [for mounting 600E] (2) 1/4-20 x 5/8" SHCS [for special safety stop] (2) 1/4-20 Nut [for special safety stop]
<b>DOVELM162</b>	16" D-style Dovetail Saddle for Losmandy D-style Plates for 900, 1200, Mach1GTO. Also for 3600GTO w/ SB3622 or SB3627 Can also be mounted on AP ring tops with blocks	(6) 1/4-20 x 1" SHCS [for mounting to 900, 1100, 1200, 1600 or Mach1 (M1 uses 4), or to attach to SBD13SS or SBD16SS] (1) 1/4-20 x 3/4" FHSCS [opt. 900, 1100, 1200 or 1600 for end positions] (4) 1/4-20 x 3/4" SHCS [for SB3622 in side-by-side configuration and for attachment to blocks for ring-top mounting]
<b>900RP</b>	15" Ribbed Plate for 900 or Mach1	(6) 1/4-20 x 1" FHSCS [for mounting to 900 or 1100] (4) 1/4-20 x 1-1/4" FHSCS [for mounting Mach1]
<b>1200RP15</b>	15" Ribbed Plate for 1200 and 1600	(6) 1/4-20 x 3/4" SHCS [for mounting to 1200 or 1600]
<b>1200RP</b>	24" Ribbed Plate for 1200 and 1600	(6) 1/4-20 x 1" SHCS [for mounting to 1200 or 1600]
<b>Q4047</b>	900/Mach1 Adapter for use with DOVE08	(6) 1/4-20 x 5/8" FHSCS [for mounting to 900 or 1100] (4) 1/4-20 x 1" FHSCS [for mounting to Mach1]
<b>SB0800</b>	7" AP-style Sliding Bar	(2) 1/4"-20 x 5/8" SHCS [for center hole in rings]
<b>SBV08</b>	8" V-Style Dovetail Plate	(2) 1/4-20 x 5/8" SHCS [for center hole in rings] (1) 1/4-20 x 3/8" SHCS [for safety stop]
<b>SBV15</b>	15" Wide-Profile V-Style Dovetail Plate	(2) 1/4-20 x 1/2" SHCS [for center hole in rings] (4) 1/4-20 x 3/4" FHSCS [for attaching directly to AP rings] (1) 1/4-20 x 3/8" SHCS [for safety stop]
<b>SBD12</b>	12" D-Style Dovetail Plate	(4) 1/4-20 x 1" low profile SHCS [for attaching the SBDAPB or LMAPBLOCKS] (4) 1/4-20 x 1-1/4" FHSCS [for attaching directly to AP Rings] (2) 1/4-20 x 1/2" SHCS [for center hole in rings] (4) 1/4-20 x 1/2" low profile SHCS (1) 1/4-20 x 3/8" SHCS [for Safety Stop]
<b>SBD16</b>	16" x 5" Wide D-style Dovetail Plate for Losmandy D-Style Dovetail Saddles	(4) 1/4-20 x 3/4" SHCS [for attaching the SBDAPB Riser Blocks] (4) 1/4-20 x 1-1/4" FHSCS [for attaching directly to AP Rings] (1) 1/4-20 x 3/8" SHCS [for Safety Stop]
<b>SBDAPB</b>	AP Riser Blocks for AP D-style Plates	(4) #10-32 x 1/2" SHCS [for attaching to mounting ring tops] (2) 1/4-20 x 1/2" SHCS
<b>SBDTB</b>	Adapter Blocks for Takahashi	(4) M10 x 20 mm SHCS [for attaching to SBD16]
<b>SBD13SS</b> <b>SBD18SS</b>	13" or 18" Side-by-Side Dovetail Plate for Losmandy D-style Dovetail Saddles	(2) 1/4-20 x 3/8" SHCS [for Safety Stops -required at both ends] (1) 1/4-20 x 5/8" SHCS [for special safety stop] (1) 1/4-20 Nut [for special safety stop]
<b>SBD2V</b>	12" Losmandy D-Style Male to Vixen V-Style Female Adapter / Sliding Bar	(1) 1/4-20 x 1/4" low profile SHCS [to replace Safety Stop on V plate] (1) 1/4-20 x 1/4" SHCS [Safety Stop for SBD2V]
<b>LT2APM</b>	Losmandy Tripod to Astro-Physics Mount Adapter Plate	(3) 5/16-18 x 5/8" SHCS (4) 1/4-20 x 5/8" SHCS (4) 1/4-20 x 1" SHCS (3) 3/8-16 x 3/4" SHCS
<b>CBAPT</b>	Control Box Adapter	(1) 1/4-20 x 3/4" BHSCS (1) 1/4-20 x 1" BHSCS (1) 5/16-18 x 1" BHSCS (2) 5/16-18 x 3/4" BHSCS (1) Washer 1/4"
<b>TRAYSB</b> <b>TRAYSB1</b>	Bi-Level Support Bar & Single Level Support Bar	(1) 1/4-20 x 1" BHSCS (1) 5/16-18 x 1" BHSCS (1) Washer 1/4"
<b>DOVEPW</b>	16.5" Dovetail Saddle for Planewave 7.652" dovetail on AP 1200, 1600 and 3600	(6) 3/8-16 x 1" SHCS (6) 1/4-20 x 1" SHCS
<b>SBPW23</b>	23" P-Style Dovetail Plate for DOVEPW	(2) 3/8-16 x 1/2" low profile SHCS (4) 1/4-20 x 5/8" SHCS
<b>DOVE3622</b>	22" Dovetail Saddle for 3600	(6) 3/8-16 x 1" SHCS (4) 3/8-16 x 1-1/2" SHCS
<b>SB3622</b> <b>SB3627</b>	Dovetail Plate for DOVE3622 Saddle	(2) 3/8-16 x 1/2" low profile SHCS (4) 1/4-20 x 7/8" SHCS for lock-down

